



Product Preview

AMAX Stereo Chipset

The MC13027 and MC13122 have been specifically designed for AM radio which can meet the EIA/NAB AMAX requirements. They are essentially the same as the MC13022A and MC13025 with the addition of noise blanking circuitry. The noise blanker consists of a wide band amplifier with an RF switch for blanking ahead the IF amplifier and a stereo audio blander with adjustable delay and blanking times.

- Operating Voltage Range of 6.0 V to 10 V
RF Blanker with Built-In Wide Band AGC Amplifier
Audio Noise Blanker with Audio Track and Hold
Mixer Third Order Intercept of 8.0 dBm (115 dBμV)
Wide Band AGC Detector for RF Amplifier
Local Oscillator VCO Divide-by-4 for Better Phase Noise
Buffered Local Oscillator Output at the Fundamental Frequency
Fast Stereo Decoder Lock
Soft Stereo Blend
Signal Quality Detector to Control Variable Q-Notch Filters for Adaptive Audio Bandwidth and Whistle Reduction
Signal Quality Detector for AM Stereo
Very Low Distortion Envelope and Synchronous Detectors
Variable Bandwidth IF

ORDERING INFORMATION

Table with 3 columns: Device, Operating Temperature Range, Package. Rows include MC13027DW, MC13027P, MC13122DW, MC13122P.

MC13027
MC13122

AMAX STEREO IC CHIPSET

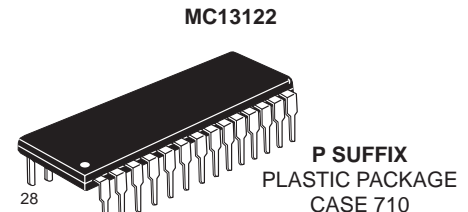
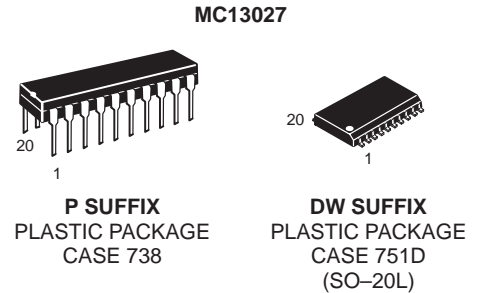

Functional Block Diagram

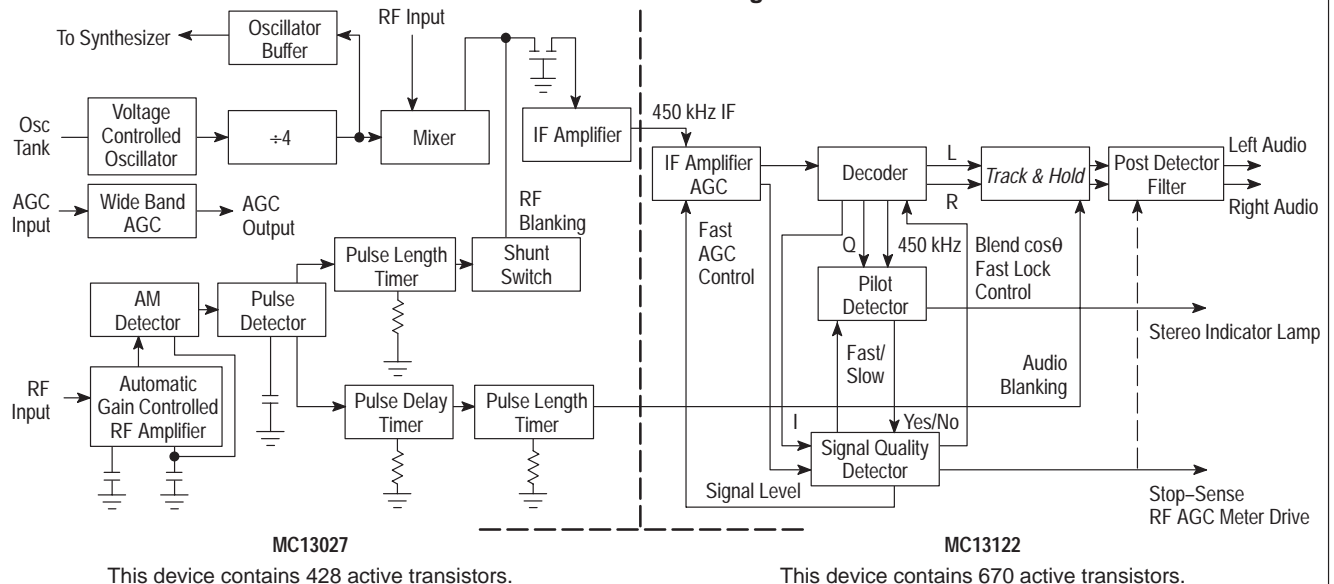

MC13027 MC13122

MC13027 MAXIMUM RATINGS

Rating	Symbol	Value	Unit
Power Supply Input Voltage	V _{CC}	12	Vdc
Ambient Operating Temperature	T _A	-40 to +85	°C
Storage Temperature Range	T _{stg}	-60 to +150	°C
Operating Junction Temperature	T _J	150	°C

NOTE: ESD data available upon request.

MC13027 ELECTRICAL CHARACTERISTICS (T_A = 25°C, 8.0 V_{CC} Test Circuit as shown in Figure 1.)

Characteristic	Min	Typ	Max	Unit
Supply Voltage Range (Pin 8)	–	6.0 to 10	–	V
Wideband (WB) AGC Threshold	–	1.0	–	mVrms
IF Output DC Current	–	1.0	–	mAdc
Mixer DC Current Output	–	0.83	–	mAdc
Local Oscillator Output	–	600	–	mVpp
Wideband AGC Pull-Down Current (Pin 20)	–	1.0	–	mAdc
Power Supply Current	–	16	–	mAdc
Mixer 3rd Order Intercept Point (Pin 6)	–	8.0	–	dBm
Mixer Conversion Gain	–	2.9	–	mS
IF Amplifier Input Impedance (Pin 14)	–	2.2	–	kΩ
IF Amplifier Transconductance	–	2.8	–	mS
IF Amplifier Load Resistance (Pin 16)	–	5.7	–	kΩ
IF Amplifier Collector Current (Pin 16)	–	990	–	μA

MC13027 MC13122

Figure 1. MC13027 Test Circuit

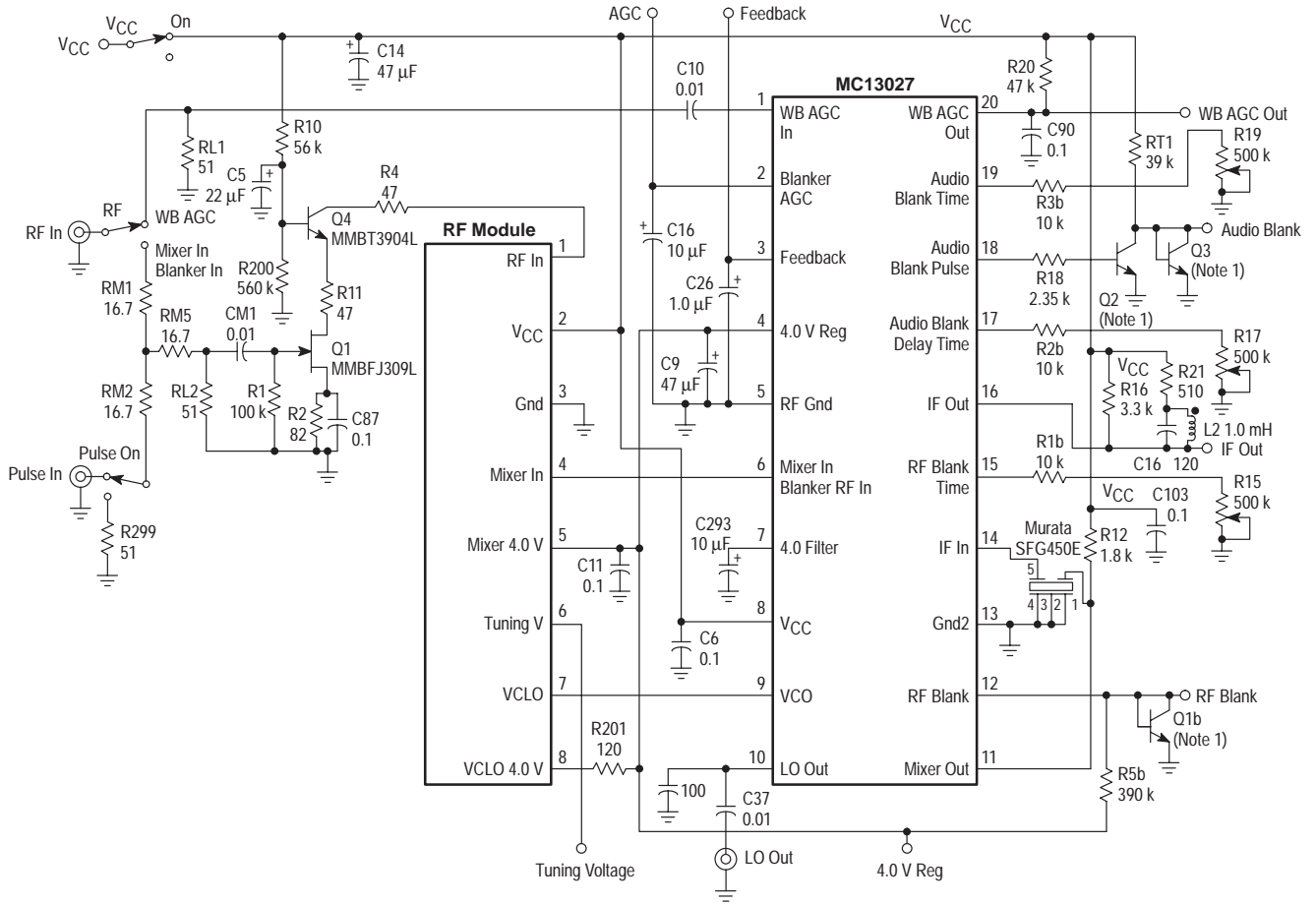

NOTE: 1. General purpose NPN transistor 2N3904 or equivalent.

MC13027 MC13122

MC13122 MAXIMUM RATINGS

Rating	Symbol	Value	Unit
Power Supply Input Voltage	V_{CC}	12	Vdc
Stereo (Pilot) Indicator Lamp Current (Pin 21)	–	30	mAdc
Operating Ambient Temperature	T_A	–40 to +85	°C
Storage Temperature Range	T_{stg}	–65 to +150	°C
Operating Junction Temperature	$T_{J(max)}$	150	°C
Power Dissipation Derated above 25°C	P_D	1.25 10	Ω mW/C

NOTE: ESD data available upon request.

MC13122 ELECTRICAL CHARACTERISTICS ($V_{CC} = 8.0$ V, $T_A = 25^\circ\text{C}$, Test Circuit of Figure 2.)

Characteristic	Min	Typ	Max	Unit
Power Supply Operating Range	6.0	8.0	10	V
Supply Current Drain (Pin 25)	10	20	25	mA
Minimum Input Signal Level, Unmodulated, for AGC Start	–	5.0	–	mV
Audio Output Level, 50% Modulation, L Only or R Only	290	400	530	mVrms
Audio Output Level, 50% Mono	140	200	265	mVrms
Output THD, 50% Modulation (Monaural Stereo)	– –	0.3 0.5	0.8 1.6	%
Channel Separation, L Only or R Only, 50% Modulation	22	35	–	dB
IF Input Voltage Range	–	1.0–1000	–	mV
IF Input Resistance Range	–	10 to 50	–	k Ω
IF Amplifier Transconductance	–	9.6	–	mS
IF Detector Circuit Impedance	–	8.3	–	k Ω
Input AGC Threshold	–	5.0	–	mV
Stop–Sense Output Range	–	2.2 to 4.0	–	V
Audio Output Impedance at 1.0 kHz (Pins 7 and 14)	–	300	–	Ω
Stereo Indicator Lamp Leakage	–	–	1.0	μA
Stereo Indicator Saturation Voltage @ 3.0 mA	–	–	200	mVdc
Oscillator Capture Range	–	± 3.0	–	kHz

MC13027 MC13122

Figure 2. MC13122 Test Circuit

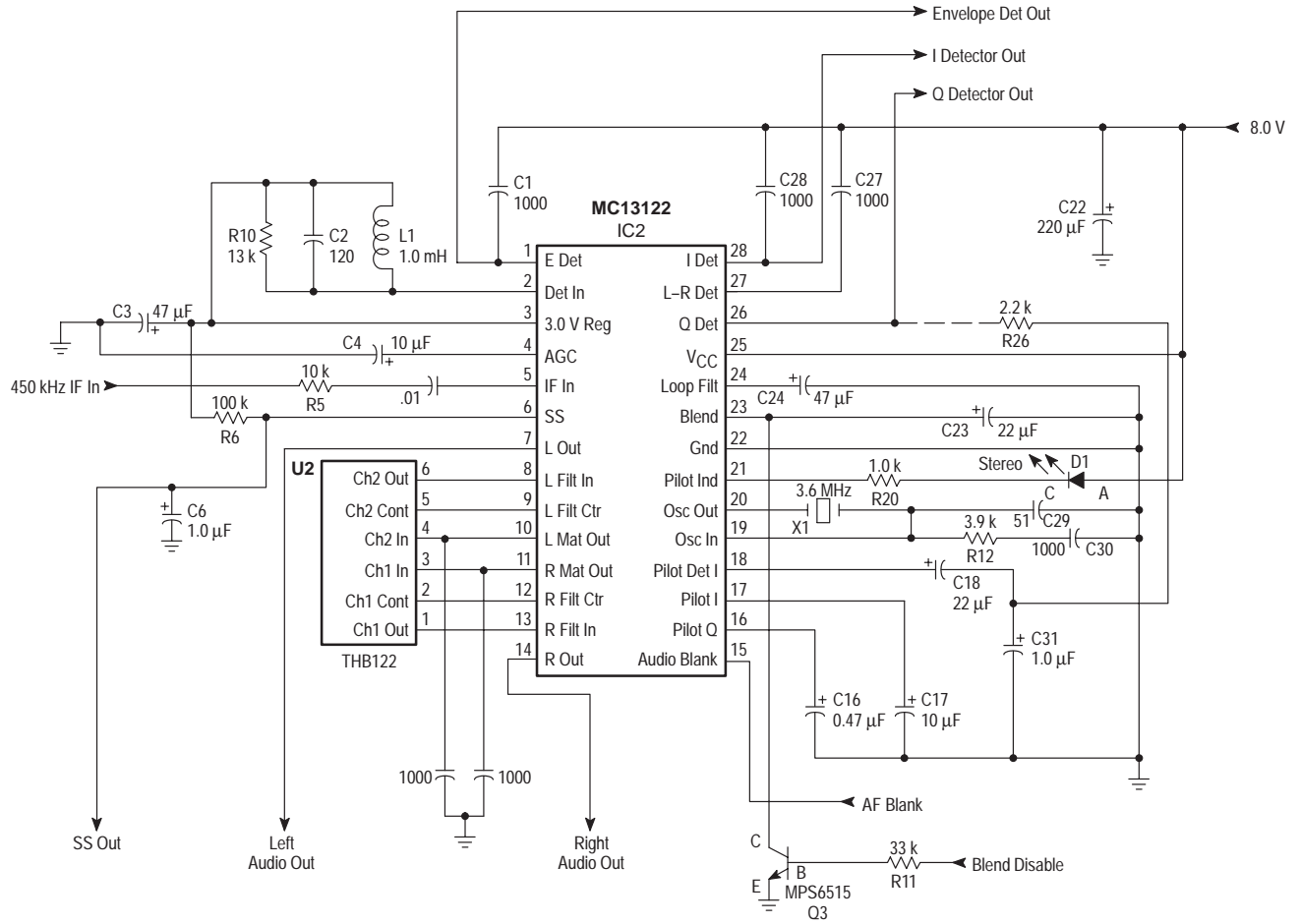

What is AMAX?

In 1993, a joint proposal by the EIA (Electronic Industries Association) and the NAB (National Association of Broadcasters) was issued. It included a unified standard for pre-emphasis and distortion for broadcasters as well as a set of criteria for the certification of receivers. The purpose of this proposal was to restore quality and uniformity to the AM band and to make it possible for the consumer to receive high quality signals using the AM band. The FCC has been supportive of this initiative and has required all new broadcast licensees to meet AMAX standards. The NAB and EIA have continued to encourage receiver manufacturers by offering the AMAX certification logo to be displayed on all qualifying radios. This logo is shown below.

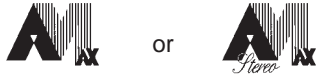

The Receiver Criteria

An AMAX receiver must have wide bandwidth: 7.5kHz for home and auto, 6.5 kHz for portables. It must have some form of bandwidth control, either manual or automatic, including at least two bandwidth provisions, such as “narrow” and “wide”. It must meet NRSC receiver standards for distortion and deemphasis. It must have provisions for an external antenna. It must be capable of tuning the expanded AM band (up to 1700 kHz). And finally, home and auto receivers must have effective noise blanking. All of these requirements, except the noise blanking, have been met by Motorola’s previous AM radio products, such as MC13025 Front End and the MC13022A C–QUAM stereo decoder. It is the Noise Blanker requirement which is met by the two devices on this data sheet, the MC13027 and MC13122.

Noise blanking, especially in AM auto radios, has become extremely important. The combination of higher energy

ignitions, using multiple spark coils, along with increased use of plastic in the auto body, have increased the noise energy at the radio. Also, the consumer has learned to expect higher quality audio due to advances in many other media. For the AM band to sustain interest to the consumer, a truly effective noise blanker is required.

The block diagram below shows the Motorola AMAX stereo chipset. It offers a two-pronged approach to noise blanking which is believed to be the most effective yet offered in the consumer market. The initial blanking takes place in the output of the mixer, using a shunt circuit triggered by a carefully defined wideband receiver. For most noises, some residual audible disturbance is almost always still present after this process. The disturbance becomes stretched and delayed as it passes through the rest of the selectivity in the receiver. The stretching and delay are predictable, so the MC13027 can provide a noise blanking pulse with the correct delay and stretch to the output stages of the MC13122 decoder. The MC13122 has a Track and Hold circuit which receives the blanking signal from the Front End and uses it to gently hold the audio wherever it is as the pulse arrives, and hold that value until the noise has passed. The combined effect is dramatic. A wide range of types of noise is successfully suppressed and the resulting audio seems almost clean until the noise is so intense that the blanking approaches full-time.

The amount of extra circuitry to accomplish noise blanking is relatively small. The external components for this added capability are shown in Figure 3. In the MC13027 Front end, the noise receiver/detector requires two capacitors. The presettings for blanking timing and blanking delay require three external fixed resistors. Finally the decoder requires two track and hold capacitors to store the “audio” voltage during the track and hold function.

Figure 3. AMAX Stereo Receiver with Noise Blanker

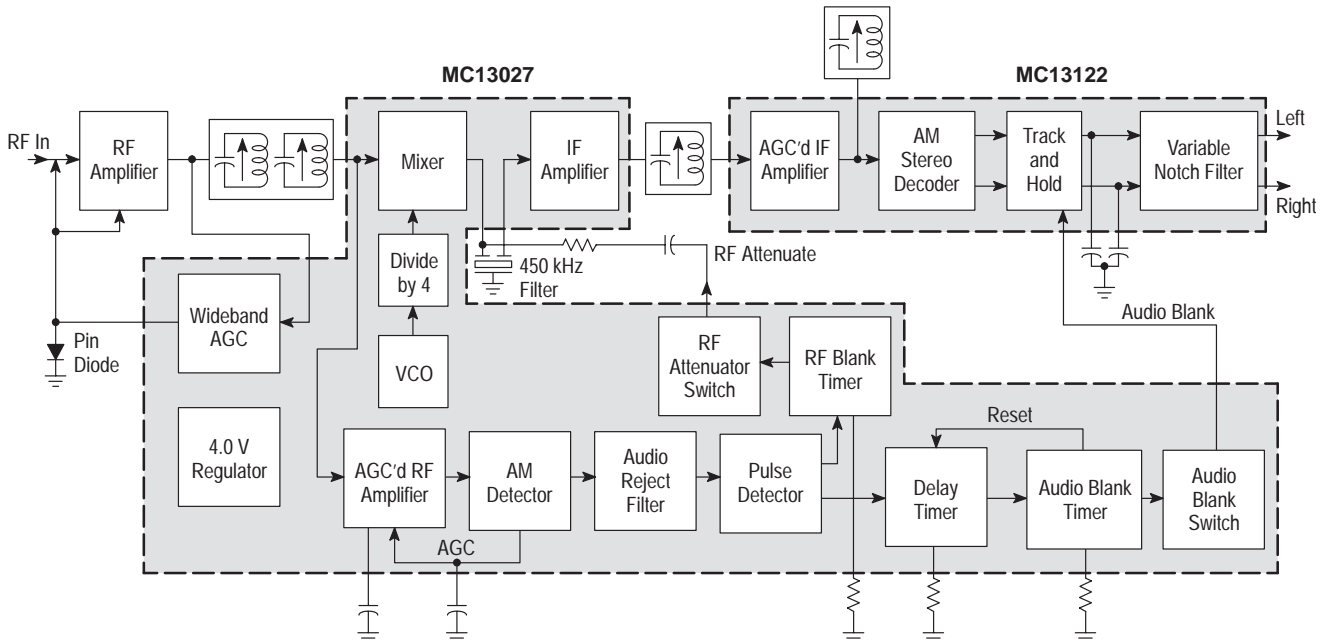
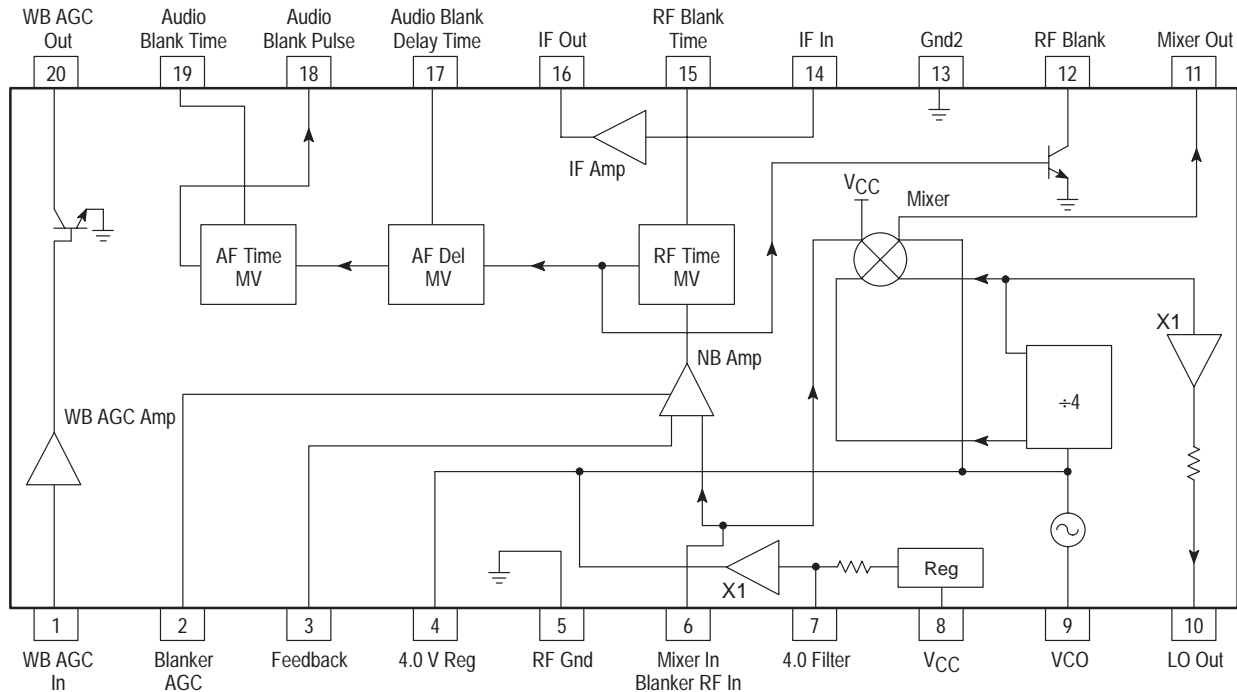

Figure 4. MC13027 Internal Block Diagram



MC13027 FUNCTIONAL DESCRIPTION

The MC13027 contains the mixer, wide band AGC system, local oscillator, IF pre-amplifier and noise blanker for an AM radio receiver. It is designed to be used with the MC13122 to produce a complete AM stereo receiver. The VCO runs at $4(F_{in} + F_{IF})$ and is divided internally by 4 for the mixer input and local oscillator buffered output. Dividing the VCO reduces the phase noise for AM stereo applications.

The noise blanker input is connected in parallel with the mixer input at Pin 6. The noise blanker circuitry contains a high gain amplifier with its own AGC so it remains linear throughout the mixer's linear range. It can detect noise pulses as low as $120 \mu\text{V}$ and generates three pulses when the noise threshold is exceeded. The width and timing of the blanking pulses is set by the resistors connected to Pins 15, 17 and 19. The resistor on Pin 15 sets the length of the RF blanking pulse and determines the time the transistor on

Pin 12 is "on". The audio blanking pulse delay is set by the resistor on Pin 17 and the width by the resistor on Pin 19. This is necessary because the IF filtering delays and stretches the noise as it arrives at the detector. The transistor on Pin 18 goes "on" to cause noise blanking in the track and hold circuit in the MC13122 (Pin 15).

Wideband AGC is used in auto receivers to prevent overload – it drives the base of a cascode transistor RF amplifier and also a pin diode at the antenna (See Figures 6 and 7).

A low gain IF amplifier between Pins 14 and 16 is used as a buffer amplifier between the mixer output filter and IF filter. The input resistance of the IF amplifier is designed to match a ceramic IF filter. The gain of the IF amplifier is determined by the impedance of the load on Pin 16.

Figure 5. MC13122 Internal Block Diagram

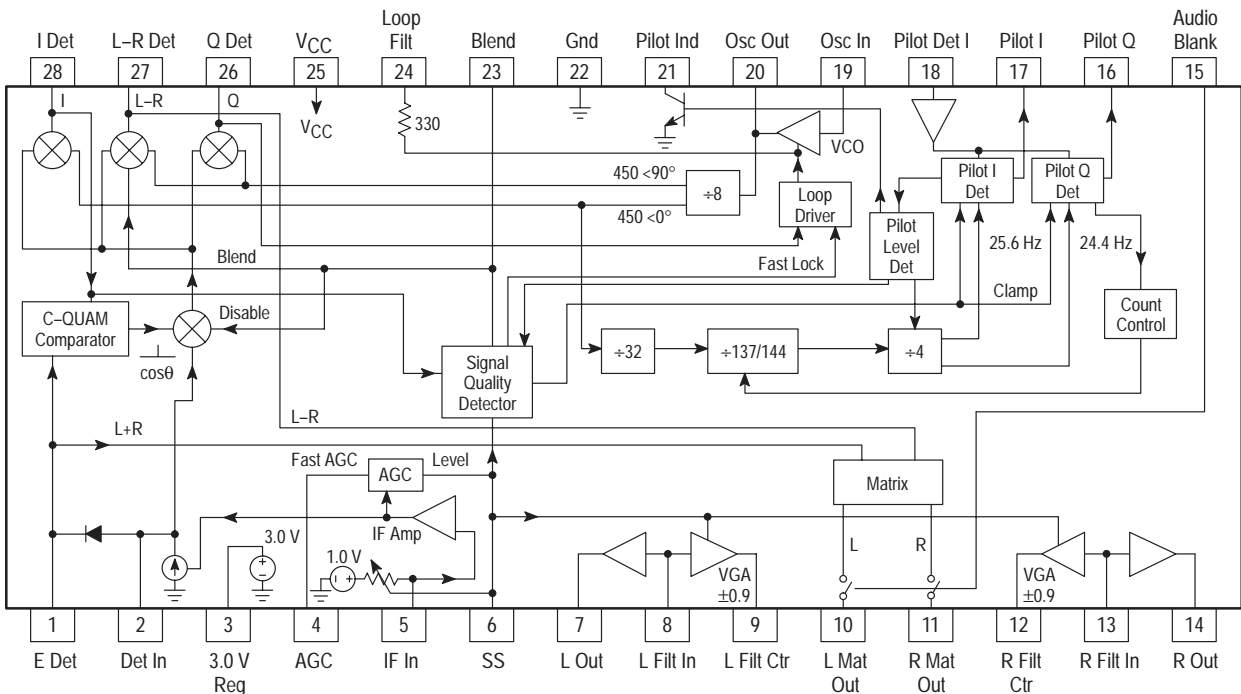

MC13122 FUNCTIONAL DESCRIPTION

The MC13122 is designed to accept a 450 kHz C-QUAM input signal from approximately 1.0 mV to 1.0 V and produce L and R audio output signals. It has additional features: stop signal, variable bandwidth IF and audio response, stereo indicator driver and track and hold noise blanking.

The IF amplifier on Pin 5 has its own AGC system. It operates by varying the input resistance on Pin 5. With weak signals below approximate 5.0 mV, the input resistance is very high and the amplifier is at maximum gain. For this AGC to be effective, it is necessary to feed the IF input signal from a relatively high impedance. The input resistance variation also reduces the Q of the coil (T1 in the application) so the receiver bandwidth is narrow for weak signals and wide for strong signals. The value of the input resistor (R5) is selected for the desired loading of the IF coil. The impedance of the IF coil on Pin 2 determines the IF gain. Pin 2 is also the input to the C-QUAM decoder.

The IF signal drives the envelope (E), in-phase (I), quadrature (Q) and (L-R) detectors. The E detector is a quasi-synchronous true envelope detector. The others are true synchronous detectors. The E detector output provides the L+R portion of the C-QUAM signal directly to the matrix. The AGC signal of the IF amplifier drives the signal strength output at Pin 6. An external resistor on Pin 6 (sets the gain of the AGC). The Pin 6 voltage is used to control the Q of the audio notch filter, causing the audio bandwidth and depth of the 10 kHz notch to change with signal strength. It is also used as one of the inputs to the signal quality detector which generates the stop-sense and blend signal on Pins 6 and 23 respectively and tells the signal quality detector that the RF input is below the AGC threshold.

VCO

The 3.6 MHz ceramic resonator on Pins 19 and 20 is part of a phase locked loop which locks to the 450 kHz IF signal. The 3.6 MHz is divided by 8 to produce in-phase and quadrature signals for the I, Q and L-R detectors. It is also divided by 32, and 137/144 to provide signals for the pilot I and Q detectors. The pilot detector is a unique circuit which does not need filtering to detect the 25 Hz pilot.

Blend Circuit

The purpose of the blend circuit is to provide an AM stereo radio with the capability of very fast lock times, protection against stereo falsing when there is no pilot present and control of the L-R signal so as to provide as much stereo information as possible, while still sounding good in the presence of noise or interference. The circuit also provides an optional stop-sense usable by a radio with seek and/or scan. The stop-sense signal provides a "stop" signal only when the radio is locked on station, signal strength is above minimum level, and the level of interference is less than a predetermined amount. The last feature prevents stopping on frequencies where there is a multiplicity of strong co-channel stations. It is common for AM radios without this capability to stop on many frequencies with unlistenable stations, especially at night.

The blend circuit controls the PLL fast lock, pilot detector, IF amplifier AGC rate, decoder L-R gain, $\cos\theta$ compensation and stop-sense as a function of the voltage on a signal external blend capacitor. Timing is determined by the rate of change of voltage on the blend cap. Timing is changed by varying charge and discharge current and pulled down by a current source, switch, and optionally an external switch. The current sources and switches are controlled by various measures of signal quality, signal strength, and presence or absence of pilot tone.

Detectors

In AM stereo operation, the Q detector delivers pilot signal via an external low-pass filter to the pilot detector input (Pin 18). The E and I detectors drive the C-QUAM comparator. The L-R signal and the output of the envelope detector are combined in the matrix to produce the L and R signals. The C-QUAM system modifies the in-phase and quadrature components of the transmitted signal by the cosine of the phase angle of the resultant carrier, for proper stereo decoding. An uncompensated L-R would be distorted, primarily by second harmonics. Where there is noise or interference in the L-R, it has been subjectively determined that reducing the $\cos\theta$ compensation at the expense of increased distortion sounds better than full decoding. The blend line operates over a small voltage range to eliminate cosine compensation.

Signal Quality Detector – Blend Voltage Control

The signal quality detector output is dependent on signal strength, over-modulation, and whether or not the blend pin has been pulled low prior to searching. Over-modulation usually occurs when a radio is tuned one channel away from a desired strong signal, so this prevents stopping one channel away from a strong signal.

In a radio tuned to a strong, interference free C-QUAM station, the blend voltage will be approximately 3.6 V. In the presence of noise or interference, when the modulation envelope is at a minimum, it is possible for the I detector to produce a negative, or below zero carrier signal. The Signal Quality Detector produces an output each time the negative I exceeds 4%. The output of the detector sets a latch. The output of the latch turns on current source which pulls down the voltage of the blend cap at a predetermined rate. The latch is then reset by a low frequency signal from the pilot detector logic. This produces about a 200 mV change each time 4% negative I is detected. Tables 1 and 2 describe the blend behavior under various conditions.

When the blend voltage reaches 2.2 V a blend control circuit starts to reduce the amplitude of the L-R signal fed to the decoder matrix. By 1.5 V the L-R has been reduced by about 40 dB. At lower voltages it is entirely off and the decoder output is monaural. This reduction of L-R signal, or blend as it is commonly called when done in FM stereo radios, reduces undesirable interference effects as a function of the amount of interference present.

Stop-Sense

Stop-sense is enabled when the blend voltage is externally pulled below 0.45 V. An input from the AGC indicating minimum signal, or detection of 10% negative I will cause the stop-sense pin to be pulled low. With signals greater than the AGC corner and less than 10% interference the stop-sense will be a minimum of 1.0 V below the 3.0 V line. Very rapid scanning is possible because the radio can scan to the next frequency as soon as the stop-sense goes low. The maximum wait time, set by the radio, is only reached on good stations.

The decoder will not lock on an adjacent channel because it is out of the lock range of the PLL. The beat note produced in the I detector by the out of lock condition will trigger the 10% negative I detector.

Sequence For Seek Scan

- Change Station – Pull-Down Blend
- Wait Approximately 50 ms for Synthesizer and Decoder PLL to Lock
- Observe Pin 6 Voltage
- If it is Above 2.0 V and Stays Above 2.0 V for Approximately 800 ms, Stay on the Station
- No IF Count Now Needed
- No AGC Level Detector Needed

Table 1. Normal Sequence When Changing Stations

External Pull-Down of Blend Capacitor to Under 0.47 V	<ul style="list-style-type: none"> – Increased Current Supplied to Loop Driver for Fast Lock – Fast AGC Activated – Extra Current Pull-Up Activated on Blend Capacitor – Pilot Detector Disabled – Loop Locks – Stop-Sense Activated
Blend Released	<ul style="list-style-type: none"> – Blend Capacitor Pulled Up to 0.7 V – Stops – Fast Lock Current Removed – Fast AGC Turned Off – Pilot Detector Enabled
Pilot Detected	<ul style="list-style-type: none"> – Stereo Indicator Pin Pulled Low – Blend Voltage Pulled Positive Rapidly
Blend Voltage Reaches 1.4 V	<ul style="list-style-type: none"> – Audio Starts Into Stereo – 10% Negative I Detector Enabled
Blend Voltage Reaches 2.2 V	<ul style="list-style-type: none"> – Stereo Separator Reaches 20 to 25 dB – Rapid Current Pull-Up Turned Off – 4% Negative I Detector Enabled
Blend Voltage Reaches 3.0 V	<ul style="list-style-type: none"> – $\cos\theta$ Enabled – Full C-QUAM Decoding – Blend Voltage Continues to Rise to 3.6 V and Stops

Table 2. Operation In Adverse Conditions

4% Negative I Detected	<ul style="list-style-type: none"> – Blend Pulls Down Approximately 200 mV for Each Event – Acts Like One-Shot – Stops at 2.2 V – $\cos\theta$ Has Been Defeated, Almost Full Stereo Remains
10% Negative I Detected	<ul style="list-style-type: none"> – Blend Pulls Down 200 mV for Each Event – Stops at 1.4 V – Stereo Has Blended to Mono – Resets Fast Pull-Up if Blend Has Not Been Above 2.2 V
50% Negative I Detected (Out of Lock)	<ul style="list-style-type: none"> – Blend Pulls Down Fast During Event – Stops at 0.47 V – Resets Fast Pull-Up – Pilot Indicator Turned Off
Minimum Signal Level Detected	<ul style="list-style-type: none"> – Resets Fast Pull-Up – Pulls Down to 0.7 V

MC13027 MC13122

MC13027 PIN FUNCTION DESCRIPTION

Pin	Name	Internal Equivalent Circuit	Description
1	WB AGC In		<p>Wideband AGC Input</p> <p>The input impedance to the WB AGC detector is 15 k and is internally biased so it must be coupled through a capacitor. The threshold can be increased by adding a resistor in series with the input. The WB AGC begins at about 1.0 mV. In car radios, this input should be connected to the collector of the RF amplifier cascode stage through a resistor and capacitor. A 68 pF to ground will prevent undesired high frequency signals from activating the WB AGC and make the sensitivity more uniform across the band.</p>
2	Blanker AGC		<p>Blanker AGC</p> <p>The capacitor to ground is the bypass for the noise blanker AGC circuit. The noise blanker can be disabled by grounding this pin. 10 μF is used in the application, but it can be changed to match the time constant of the main IF AGC in the MC13122, Pin 4.</p>
3	Feedback		<p>Blanker Feedback</p> <p>This pin is the dc feedback to the input stage of the wide band amplifier.</p>
4	4.0 V Reg		<p>4.0 V Regulator</p> <p>The 4.0 V regulator supplies low impedance bias to many of the circuits in the IC. It should be bypassed to a ground near Pin 5.</p>
7	4.0 V Filt		<p>4.0 V Filter</p> <p>The external capacitor works with internal 4.7 k to filter noise from the bandgap regulator.</p>
5	Gnd		<p>RF Ground</p> <p>This pin is the ground for the RF section, blanker RF, filters and all radio circuits except the IF. In the PCB layout, the ground pin should be used as the internal return ground in the RF circuits.</p>
6	Blk _{RF} /Mix _{In}		<p>Mixer Input/Blanker RF Input</p> <p>The blanker RF input must be biased from the 4.0 V on Pin 4. The mixer input is to two bases of the upper mixer transistors. A low impedance dc path to the 4.0 V on Pin 4 is required. Normally, this would be a coil secondary connected between Pins 6 and 4.</p>
11	Mixer Out		<p>Mixer Output</p> <p>A single ended output of a double balanced mixer. A load resistor to supply is chosen to match the ceramic filter, typically 1.5 k to 1.8 k. Output current is 830 μA.</p>

MC13027 MC13122

MC13027 PIN FUNCTION DESCRIPTION (continued)

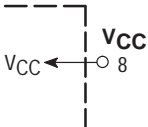
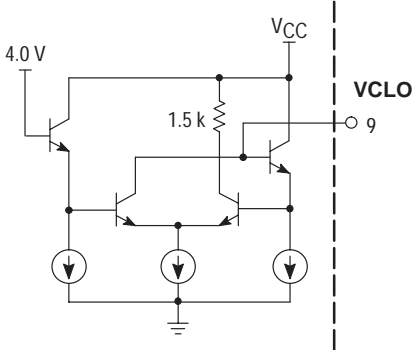
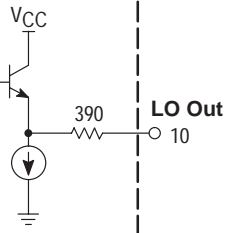
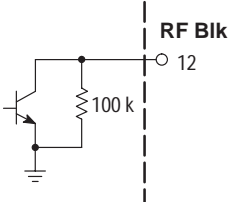
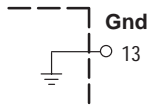
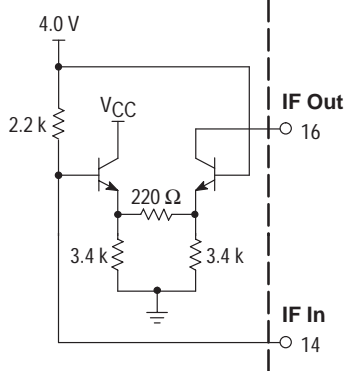
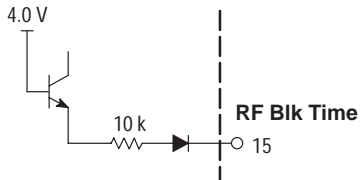
Pin	Name	Internal Equivalent Circuit	Description
8	V _{CC}		Supply Voltage The normal operating voltage range is 6.0 to 10 V.
9	VCLO		Voltage Control Local Oscillator The oscillator is a cross coupled negative resistance type and this pin must be connected through a low dc resistance to Pin 4, the 4.0 V regulator. Normally, this would be the secondary of the oscillator coil. The impedance of the secondary winding should be around 2.8 kΩ to guarantee that the oscillator will run. It operates at 4 times the LO frequency: $f_{osc} = 4(F_{in} + F_{IF})$.
10	LO Out		Local Oscillator Output This is an emitter follower for LO output to drive a synthesizer. It is a square wave output, the internal series resistance and allows a small bypass to reduce high frequency harmonics.
12	RF Blank		RF Blanker An unbiased NPN acts as a SHUNT impedance when turned on. The 100 k resistor provides a dc path for the capacitor.
13	Gnd2		IF Ground Pin 13 is the ground for the IF section and the timing and switching circuits in the blanker. In the application circuit this should be common to the MC13122 ground.
14	IF In		IF Input A degenerated differential amplifier internally biased to 4.0 V. The IF input impedance is approximately 1.8 k to match a ceramic filter. The IF amplifier is used as a buffer between the ceramic filter and the detector coil and has a fixed gain determined by the impedance of the output coil.
16	IF Out		IF Output An open collector provides high-impedance drive to the MC13122; the IF gain is set by the ac impedance on this pin.
15	RF Time		RF Blank Time A resistor to ground sets the RF blanking time. The time is set to the minimum required to attenuate the pulse received. This is normally longest at the low end of the band. The value is best approved by ear. A fixed value can be chosen for production. (50 μs is typical.)

MC13027 MC13122

MC13027 PIN FUNCTION DESCRIPTION (continued)

Pin	Name	Internal Equivalent Circuit	Description
17	Delay Time		<p>Audio Blank Delay Time</p> <p>A resistor to ground sets the delay time from the beginning of the RF blanking pulse to the beginning of the audio blanking pulse. This normally is about $50 \mu\text{s}$ for a wide AMAX filter. The ear is the most sensitive measure of the correct delay; start low, say $20 \mu\text{s}$, and vary delay until noise is heard, and then reduce somewhat.</p>
18	Audio Blank Cntl		<p>Audio Blank Pulse</p> <p>When the blanker is operating, a positive pulse from this pin is fed to Pin 15 of the MC13122 to blank the audio signal.</p>
19	Audio Time		<p>Audio Blank Time</p> <p>A resistor to ground sets the width of the blanking pulse on Pin 18. This is usually selected by applying a pulse to the antenna of the receiver and adjusting a variable resistor. The blanking signal should be just long enough to suppress the audio pulse. Again the ear is the most sensitive tool. Start long, approximately $250 \mu\text{s}$ and reduce until noise is audible then increase.</p>
20	WB AGC Out		<p>Wideband AGC Output</p> <p>A push-pull current output. The resistor to voltage source (normally V_{CC}) determines the gain. Used to bias a cascode transistor in series with the input FET and can also be used to drive a PNP transistor which drives a pin diode attenuator (refer to Application Circuit Figure 6.)</p>

MC13027 MC13122

MC13122 PIN FUNCTION DESCRIPTION

Pin	Name	Internal Equivalent Circuit	Description
1	E Detector		<p>Envelope Detector</p> <p>This is the output of the envelope detector and is used for one input to the comparator that generates $\cos\theta$ signal and the L+R input to the matrix. It is a quasi-synchronous full wave detector with very low distortion (<1% at 100% modulation). The output impedance is 6.2 k, and it is bypassed to V_{CC} with 1.0 nF to eliminate 900 kHz components. The bypass capacitor must be the same as the one on Pin 27 and 28 for lowest stereo distortion and best separation.</p>
2	Detector In		<p>IF Out/Decoder Input</p> <p>The IF coil is connected from Pin 2 to Pin 3, the 3.0 V regulator. The IF amplifier output is a current source. The gain is determined by the impedance between Pins 2 and 3. Bandwidth and gain is set by the resistance across the coil.</p>
3	3.0 V Reg		<p>3.0 V Regulator</p> <p>This bandgap regulator supplies bias to many of the circuits in the IC.</p>
4	AGC Byp		<p>IF AGC Bypass</p> <p>The AGC has a fast and slow time constant. The fast AGC is 18X the slow one and is active when the 450 kHz loop is not locked. This allows for fast scanning in car radios. This capacitor should be selected for distortion for low frequencies at 80% modulation.</p>
5	IF In		<p>IF Input</p> <p>The IF AGC varies the current through attenuator diodes. The diodes vary the input impedance shunting the IF signal. The varying impedance also varies the Q and therefore the bandwidth. The IF AGC is accomplished by turning on the diodes and lowering the IF input impedance.</p>

MC13027 MC13122

MC13122 PIN FUNCTION DESCRIPTION (continued)

Pin	Name	Internal Equivalent Circuit	Description
6	SS		<p>Signal Strength/Stop-Sense</p> <p>The signal strength is a push-pull circuit. The voltage is 2.2 V at minimum signal and 3.5 to 5.0 V at strong signal. This dc voltage is also used to control the audio output notch filters. If the Blend pin is low the stop-sense is activated and this pin can go low. This can be used to control the seek-scan in the radio.</p>
7 14	Left Out Right Out		<p>Filtered Left and Filtered Right Output</p> <p>This can drive a de-emphasis filter to bring audio contour to AMAX specifications. Since the output is an emitter follower, the output impedance is low, and a series R should be used with the de-emphasis network as shown on the application circuit.</p>
8 13	L Filt In R Filt In		<p>Input to Notch Filter</p> <p>DC bias is supplied through the external filter components.</p>
9 12	L Filt Ctr R Filt Ctr		<p>Left Filter and Right Filter Center</p> <p>Drives the center leg of a twin-T filter, varying the Q. At strong signal, positive feedback narrows the notch, and there is little HF roll-off. At weak signal, negative feedback produces a broad notch and HF roll-off.</p>
10 11	L Matrix Out R Matrix Out		<p>Track and Hold Output</p> <p>This is a unity gain operational amplifier output. The current is turned off by the blanking pulse. The capacitor holds output voltage constant until unblanked. Internal feedback causes the output impedance to be low.</p>
15	AF Blank In		<p>Audio Blank Control</p> <p>The current to the output drivers is turned off.</p>

MC13027 MC13122

MC13122 PIN FUNCTION DESCRIPTION (continued)

Pin	Name	Internal Equivalent Circuit	Description
16	Pilot Q		<p>Pilot Q</p> <p>This is the output of a quadrature detector of a narrowband phase locked loop system.</p> <p>It is used to control the pilot detector circuitry. The pilot Q is clamped to the 3.0 V reference when the blend voltage is pulled low. This results in faster pilot detection when a stereo station is tuned in. If the blend is not pulled low, the pilot Q will drift up approximately 0.5 V when there is no pilot, and it will take longer to detect the pilot. The capacitor to ground is the loop filter. It sets the pilot loop bandwidth: if it is too large, the loop bandwidth maybe too small, and the pilot may not be re-acquired if it is lost unless the blend pin is externally pulled low again.</p>
17	Pilot I		<p>Pilot I</p> <p>When the loop is locked to a 25 Hz AM stereo pilot, this is the output of an in-phase synchronous detector. The capacitor filters the output, which is used to drive the pilot indicator driver on Pin 21. The time constant for the pilot indicator output is determined by this capacitor and the internal 47 k resistor. If the capacitor is too small, it can lead to pilot falsing due to noise. If the capacitor is too large, the acquisition time increases. The cap is charged to 3.0 V when the blend voltage is low to shorten lock time.</p>
18	Pilot Det In		<p>Pilot Detector Input</p> <p>The pilot detector will detect a pilot tone between 24.4 and 25.6 Hz. The pilot signal is fed from Q detector through a low pass filter on Pin 26. The audio signals from the Q detector must be filtered out, so a low-pass filter is used. The capacitor in series with Pin 18 blocks dc and prevents large low frequency transients from knocking the decoder out of stereo mode.</p>
19	Osc In		<p>Oscillator Input</p> <p>The input impedance is 10 k, but the recommended circuit adds 3.9 k in parallel with this to control the capture range of the VCO to be around ± 3.0 kHz. using the recommended ceramic resonator.</p>
20	Osc Out		<p>Oscillator Output</p> <p>The internal phase shift of the VCO is 90 degrees, and the output impedance is low. It is designed to drive a resonant circuit with a 90 degree phase shift at the center frequency.</p>

MC13027 MC13122

MC13122 PIN FUNCTION DESCRIPTION (continued)

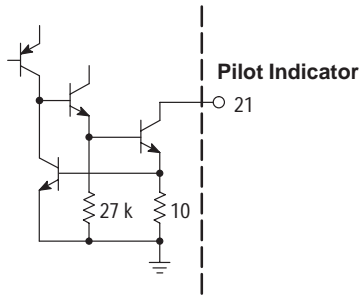
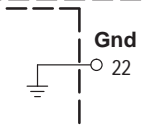
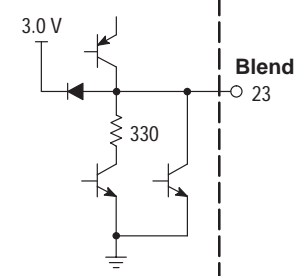
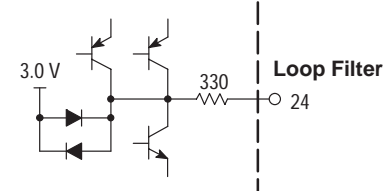
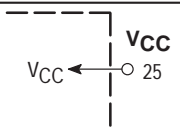
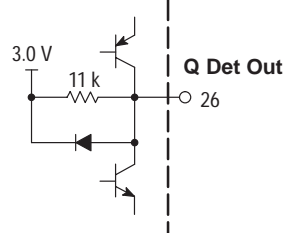
Pin	Name	Internal Equivalent Circuit	Description
21	Pilot Indicator		<p>Pilot Indicator</p> <p>The maximum current is internally limited to protect the IC, but it should be operated with a current limiting resistor.</p>
22	Gnd		<p>Ground</p> <p>Use good practices to keep oscillator returns and RF bypasses to good copper near this point</p>
23	Blend Cont		<p>Blend Control</p> <p>There are pull-up and pull-down currents provided to this pin. The external capacitor controls the rate of change of this voltage and 22 μF is recommended. This is an important voltage affecting many functions in the IC.</p>
24	Loop Filt		<p>Loop Filter</p> <p>The phase detector is a current source, so only a single RC loop filter is needed for a second order loop. The internal 330 Ω resistor together with a 47 μF gives the correct corner frequency and damping for the proper operation on the decoder loop. The cap should be low leakage to avoid static phase error.</p>
25	VCC		<p>VCC</p> <p>The operating voltage is normally 8.0 to 10 V in car radios. The MC13122 will work from 6.0 to 10 V.</p>
26	Q Detector		<p>Q Detector Output</p> <p>This is a synchronous detector in quadrature with the 450 kHz IF signal. The output impedance is 11 k. This signal is normally used for input to the pilot detector and internally for the fast lock.</p>

MC13027 MC13122

MC13122 PIN FUNCTION DESCRIPTION (continued)

Pin	Name	Internal Equivalent Circuit	Description
27	L-R Detector		<p>L-R Detector</p> <p>This is similar to the Q detector output but its level is controlled by the blend circuit. When the blend is active, the L-R output is reduced in level by reducing the dc current until mono operation is reached. It operates in the same way as the blend circuit in FM stereo decoders. The bypass capacitor should be 1.0 nF as on Pin 1 for optimum channel separation.</p>
28	I Detector		<p>I Detector</p> <p>This is a synchronous detector in phase with the 450 kHz IF signal. It is used internally to generate the $\cos\theta$ signal and as an input to the signal quality detector. The bypass capacitor should be the same as the one on Pin 1 for best separation and lowest stereo distortion.</p>

MC13027 MC13122

CAR RADIO APPLICATION

Figure 6 shows a car radio circuit using a TOKO pre-tuned RF module. The RF module includes a 4 diode tracking circuit to eliminate mistracking between the oscillator and RF circuits over the 530 to 1700 kHz AM band. This is important for stereo performance because mistracking will cause mono distortion and will significantly reduce the stereo separation. The THB122 module contains the variable 10 kHz notch filter. This module can be replaced with discrete components as shown in Figure 8, using 1% resistors and 5% capacitors.

Some manufacturers add a PIN diode attenuator at the antenna input. An example is shown in Figure 7.

The WB AGC sensitivity can be adjusted by changing R4 in series with the WB AGC input, Pin 1. The internal input resistance is 15 k.

R15, R17 and R19 are the blanker timing resistors. They were setup for this circuit and can be changed if desired.

FL1 is a linear phase IF filter. We recommend a Gaussian (rounded) filter, such as SFG or SFH for lower distortion and better separation than one with a flatter amplitude response. The SFG types of filters have poorer selectivity than the ones with flat GDT (group delay time) so some compromise has been made on adjacent channel selectivity.

The blanker can be disabled for testing by grounding the blanker AGC on Pin 2 in the MC13027.

The blanker and mixer inputs must be biased from the 4.0 V regulator through a low dc resistance like the secondary winding of the RF coil.

The receiver VCO operates at 4 times the local oscillator frequency and is divided internally in the MC13027 so that both the mixer input and the LO out is the same as in other receivers. This receiver can be connected to an existing synthesizer. For AM stereo, the synthesizer must have low phase noise. The Motorola MC145173 is recommended. For bench testing of this receiver, the Motorola MC145151 parallel input synthesizer may be useful. It will operate on 9.0 V and the phase detector can provide tuning voltage without a buffer amplifier.

The SS (stop-sense) output can be used for station searching and scanning. The best way to use it is to connect the SS signal to a comparator or A-D converter in the control microprocessor. If Pin 23 is grounded during searching by turning on Q3, the SS voltage changes from less than 0.5 V to around 2.2 V when an RF threshold is exceeded, as is shown in the graph in Figure 15. This system results in very reliable stopping on usable signals and fast detection of AM stereo signals. After a station is detected, Q3 should be turned off.

This receiver is very easy to set up because the TOKO module is pre-aligned. The only adjustments are to tune T1 and T2 for maximum voltage of the SS out line or maximum audio with a weak signal. If desired, they can be changed slightly to maximize stereo separation.

If different components are used, the blanker resistors can be setup as follows:

Ground Pin 2 of the MC13027. Apply a 1.0 μ s pulse or 50 Hz square wave of about 10 mV through a dummy antenna and synchronize an oscilloscope to the pulse generator. Observe the signal at the mixer collector (Pin 11). It should be a sine wave burst. Remove the ground on Pin 2 and adjust R15 so the burst is just suppressed. Check the performance at the ends and middle of the band because the width might change due to RF circuit bandwidth.

Mix the pulse signal with a CW signal of about 300 μ V with a power combiner and connect the oscilloscope to Pin 7 or Pin 14 of the MC13122. Adjust R17 so the blanking starts at the beginning of the audio pulse and R19 so the audio blanking is just long enough to suppress the audio pulse. The audio blanking time should not be made longer than necessary because it will be more noticeable in the normal program. The effectiveness of the blanker can be determined in field testing by connecting a switch from Pin 2 of the MC13027 to ground and bringing it outside the radio.

Figures 10 to 19 refer to the performance of the Application Circuit of Figure 6.

Figure 6. AMAX Chipset Application Circuit

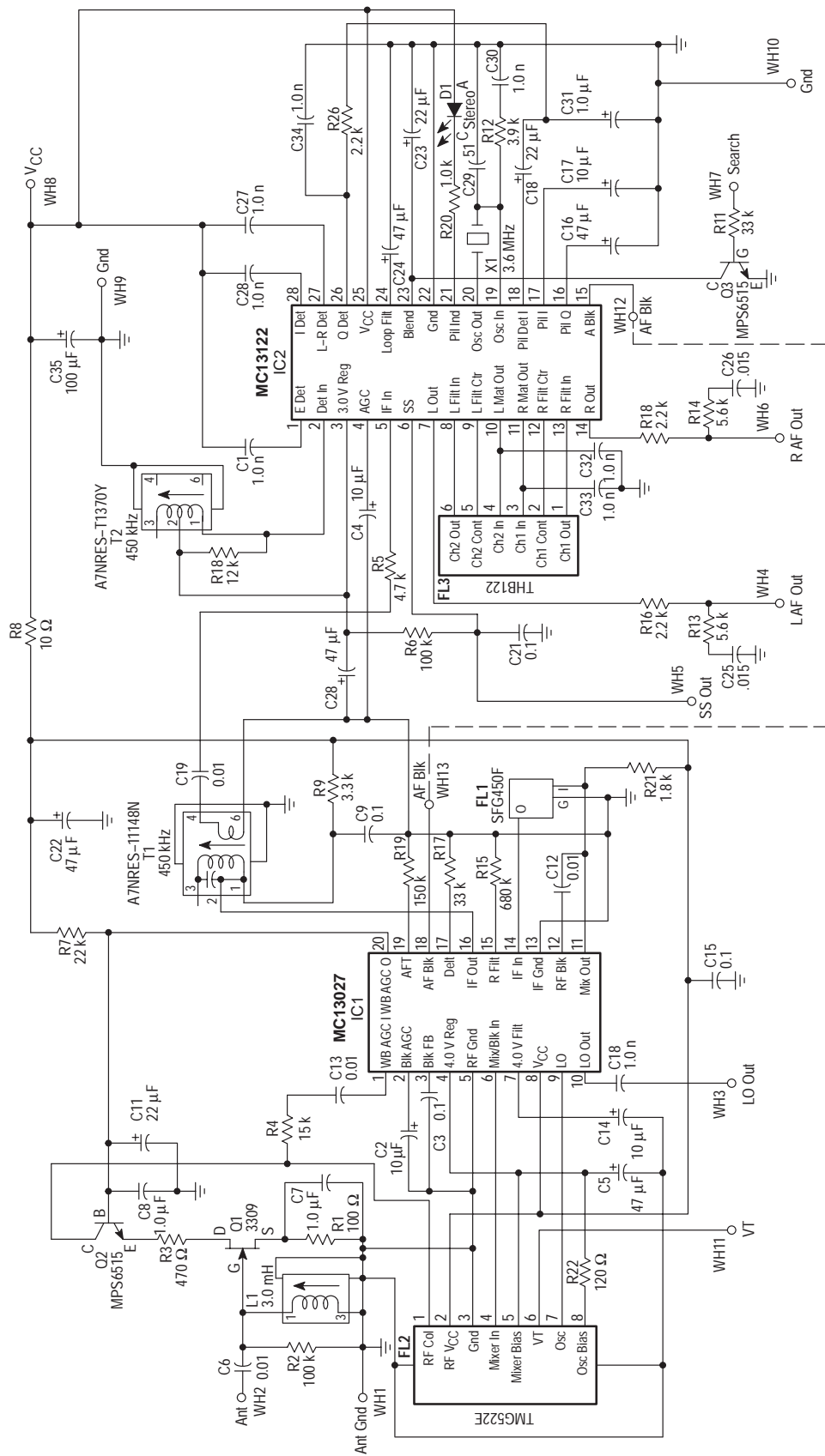

Figure 7. RF Pin Diode

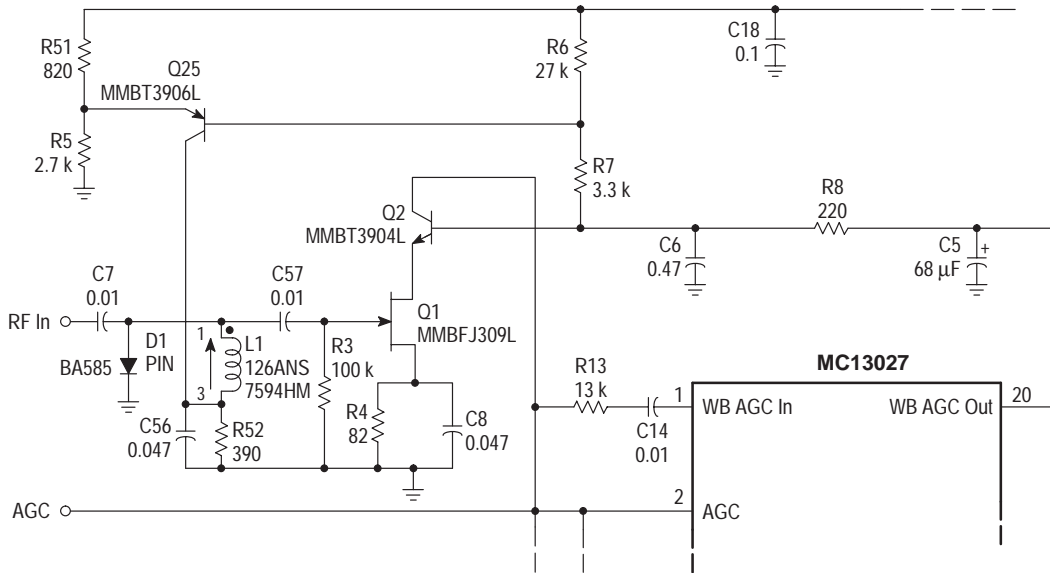

Figure 8. MC13027/MC13122 Discrete RF and Notch Filters

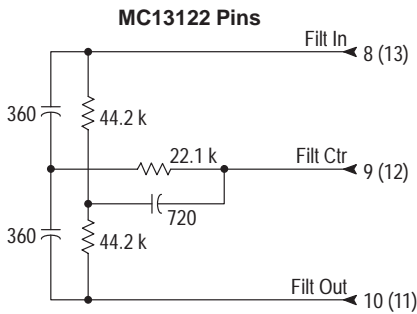

Figure 9. Overall Selectivity of a Typical Receiver versus Filter Control Voltage

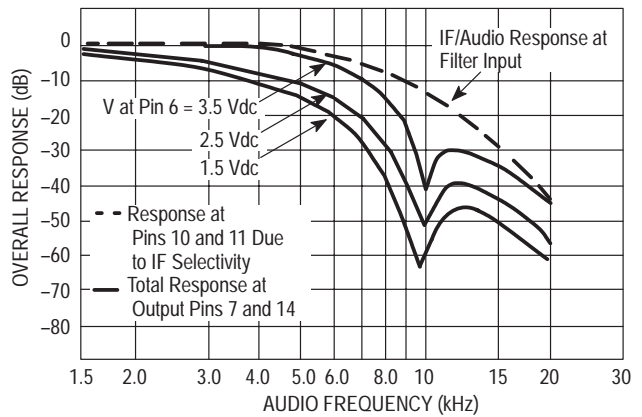
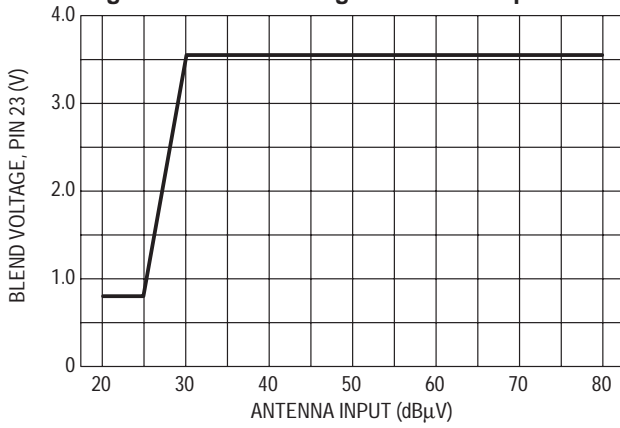
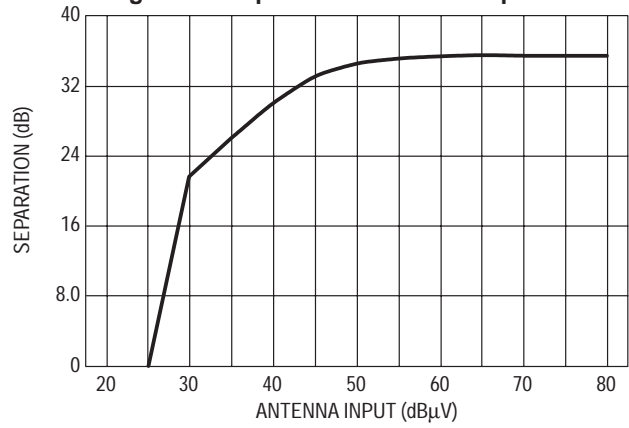

Figure 10. Blend Voltage versus RF Input Level



NOTE: The graphs on this page were made using the 15/60 pF dummy antenna and the Application Circuit of Figure 6.

Figure 11. Separation versus RF Input Level



NOTE: The radio stays in mono until the stereo signal is sufficiently large and then makes a smooth transition to stereo. This is similar to FM receivers with variable blend.

Figure 12. Signal to Noise versus RF Input Level

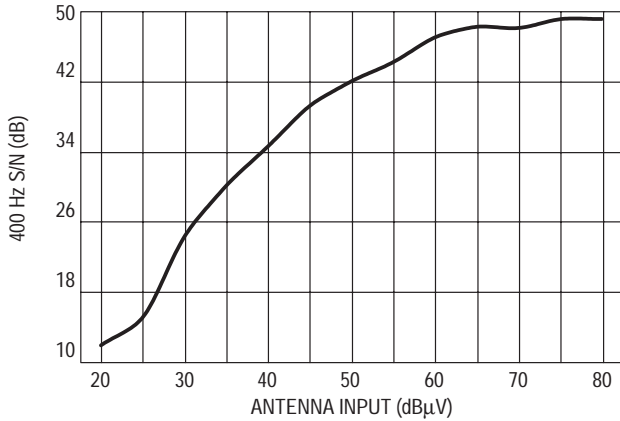

NOTE: The slightly abrupt change at around 25 dBμV is due to the decoder switching into stereo.

Figure 13. 5.0 kHz Attenuation versus RF Input Level

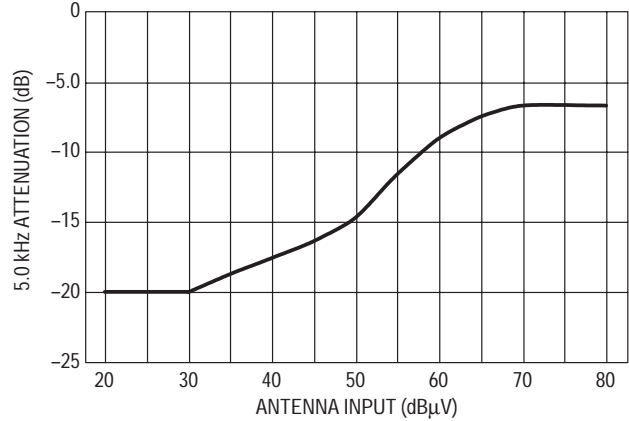

NOTE: This curve shows the effect of the variable audio bandwidth control of the MC13122. It is due to the variable loading of the IF coil and the variable 10 kHz notch filter in the output.

Figure 14. Audio Output Level versus RF Input Level

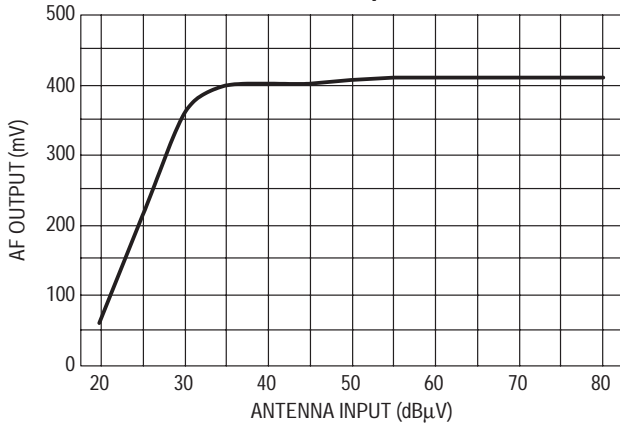

NOTE: All the curves of performance versus RF input level were generated using the car radio receiver circuit shown in Figure 6. Using a 15/60 pF dummy antenna input and a 50% L only stereo signal.

Figure 15. Stop-Sense Voltage versus RF Input Level

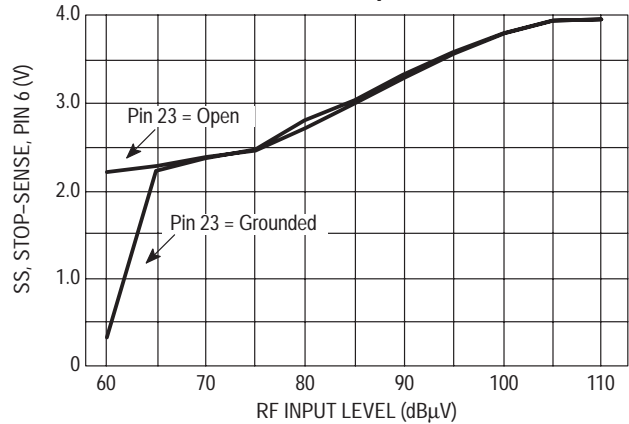

NOTE: This measurement was made on the MC13122 alone with a 10 k series input resistor. It will enable the designer to determine the stop-sense level if the gain of receiver RF section is known. Note that if Pin 23 is held low, the SS voltage on Pin 6 rises from about 0.3 to 2.2 V over a small change in RF level. This can be used to generate a very reliable stop signal. If Pin 23 is not held low, the SS voltage starts out at 2.2 V and rises slowly to a maximum of around 4.0 V.

Figure 16. Audio Blanking Delay versus R17

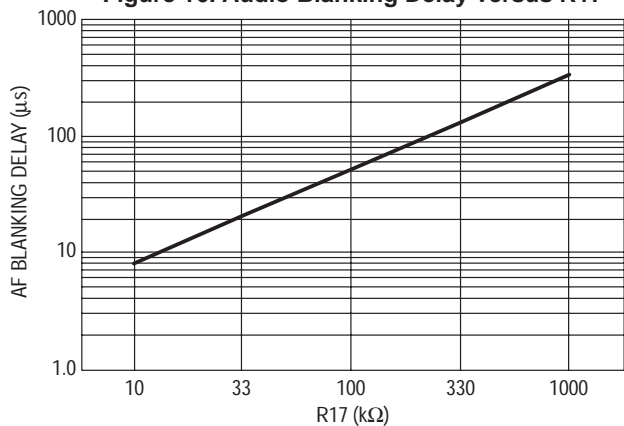

Figure 17. RF Blanking Time versus R15

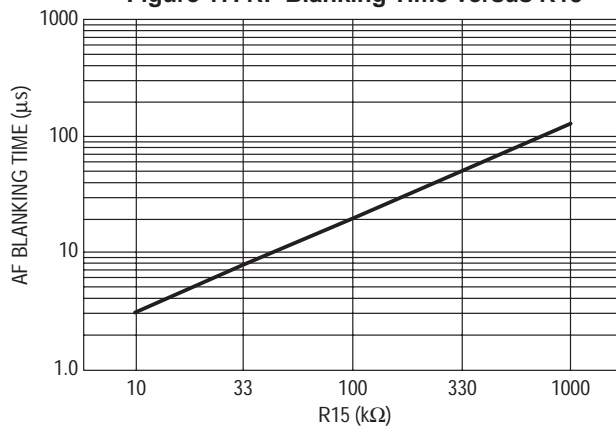

Figure 18. Audio Blanking Time versus R19

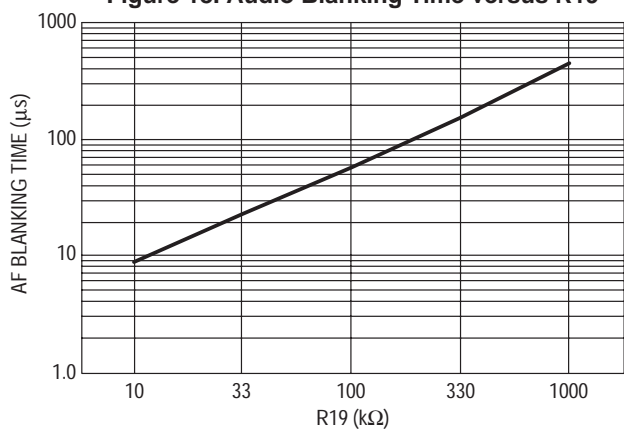
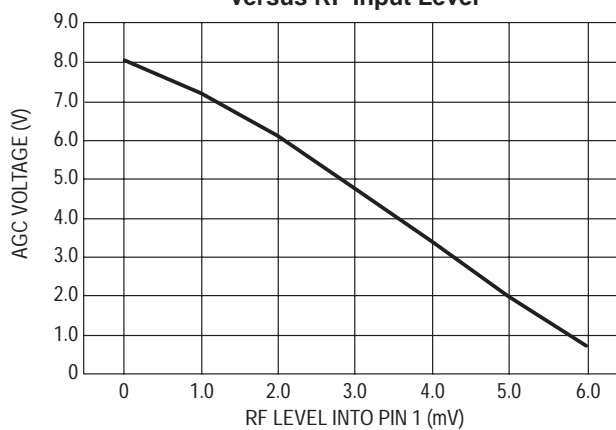

Figure 19. WB AGC Output Voltage (Pin 20) versus RF Input Level



NOTE: This was measured by applying an RF signal through a capacitor directly to Pin 1. The input resistance is 15 k, so the desired threshold can be increased by adding a resistor in series with the input.

MC13027 MC13122

AMAX STEREO CHIPSET

The RF Module

In the early development phase of this AMAX Stereo Chipset, Motorola worked with TOKO America Inc. to develop an RF tuning module. Part number TMG522E was assigned and is available from TOKO now. This module provides the "tracked" tuning elements for the RF (T1 and T2 and associated capacitors and varicaps) and the VCO (T3 et al). Some radio designers may prefer to develop their own tuning system using discrete coils and components, but the TOKO approach offers good performance, compactness and ease of application. Motorola recommends that every designer use this approach at least for initial system development and evaluation.

As refinement of the application progressed, it was found that a modification of the TMG522E was needed which would reduce the amount of VCO leakage into the Mixer through the

power supply connections. This modification is described below. Motorola will work with TOKO to develop a new part number incorporating this change. In the meantime, it is necessary that the user perform these simple changes, because the radio circuits throughout this data sheet assume this modified design.

Modifying the TMG522E

Referring to Figures 20 and 21, there are three simple steps to the modification:

1. Cut the thin copper trace from Pin 2 to Pin 5 as shown.
2. Cut the thin copper trace from Pin 8 to the bottom of the 120 Ω resistor. Removal of the resistor is optional.
3. Connect a wire from Pin 5 to the top of the 120 Ω resistor (or the upper pad for the resistor).

Figure 20. TMG522E Schematic

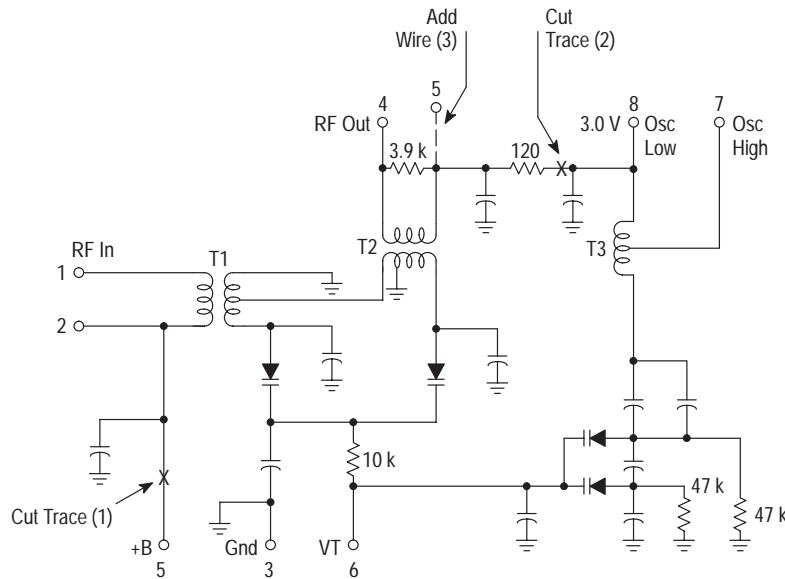
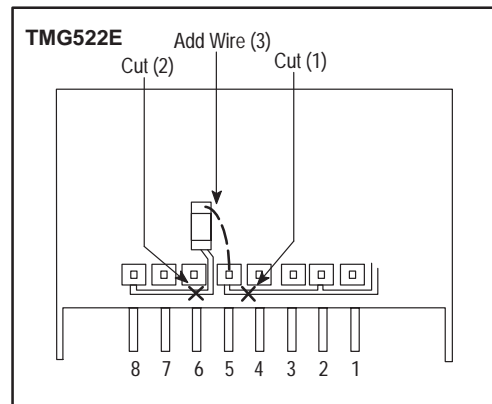
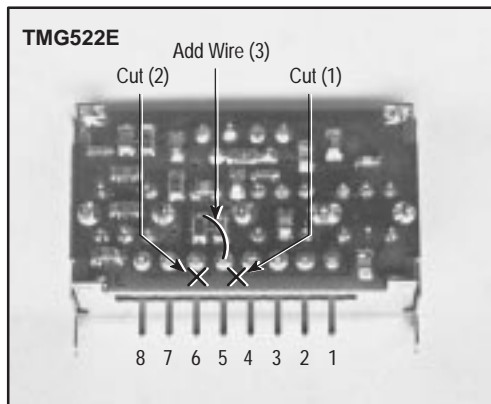

Figure 21. TMG522E Physical Modifications



MC13027 MC13122

Figure 22. AMAX Chipset Printed Circuit Board
(Top View)

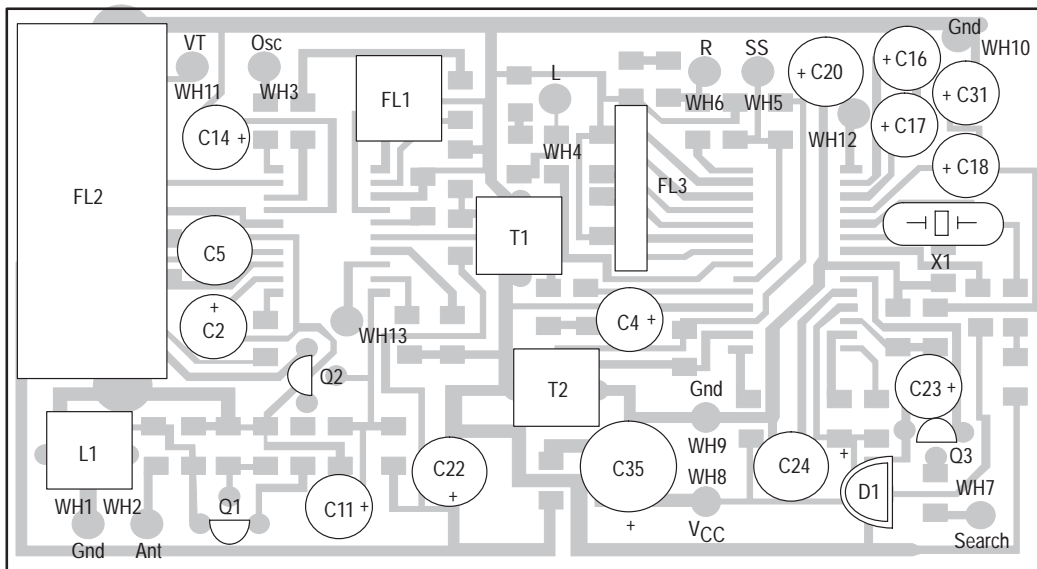

Figure 23. AMAX Chipset Printed Circuit Board
(Bottom View)

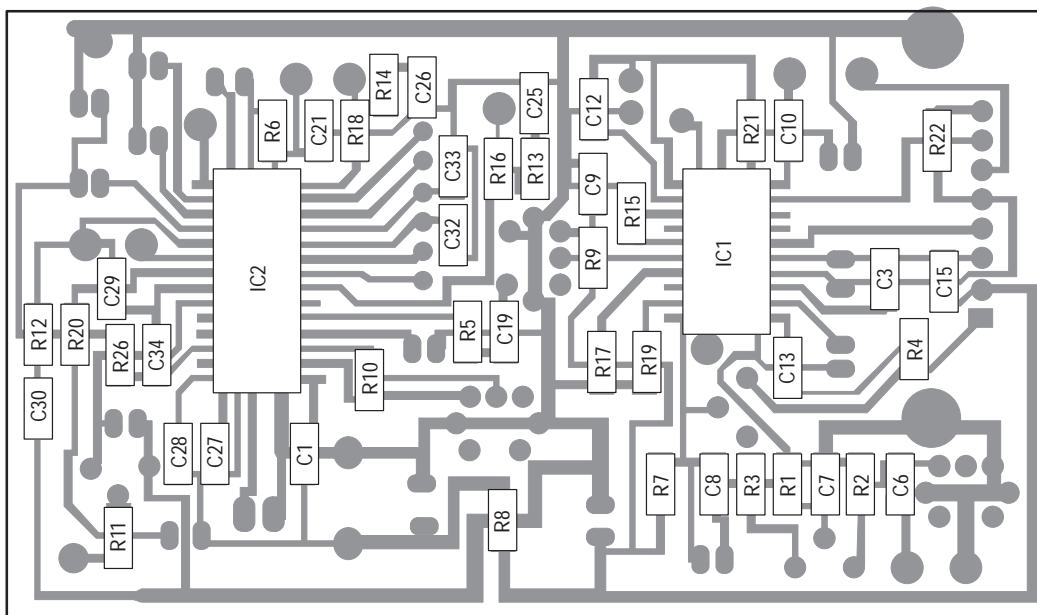
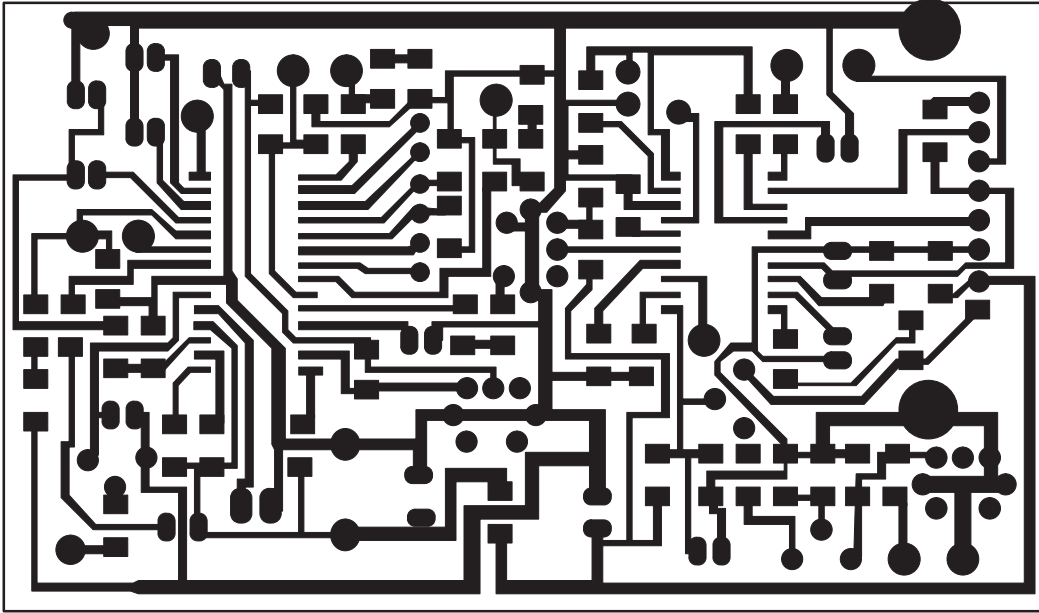

Figure 24. AMAX Chipset Printed Circuit Board
(Copper View)



Tape and Reel Options

In Brief . . .

Motorola offers the convenience of Tape and Reel packaging for our growing family of standard integrated circuit products. Reels are available to support the requirements of both first and second generation pick-and-place equipment. The packaging fully conforms to the latest EIA-481A specification. The antistatic embossed tape provides a secure cavity, sealed with a peel-back cover tape.

	Page
Tape and Reel Configurations	12-2
Tape and Reel Information Table	12-4
Analog MPQ Table	12-5

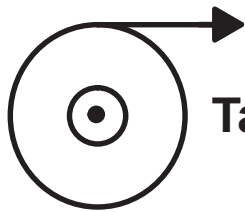

Tape and Reel Configurations

Mechanical Polarization

SOIC and Micro-8 DEVICES

Typical

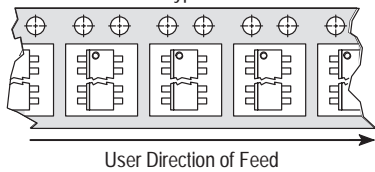

PLCC DEVICES

Typical

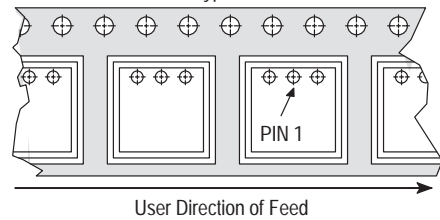

DPAK and D²PAK DEVICES

Typical

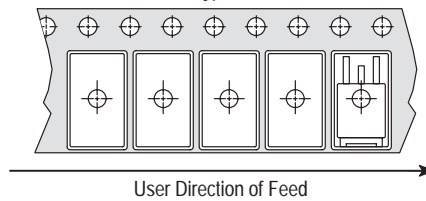

SOT-23 (5 Pin) DEVICES

Typical

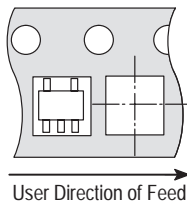

SOT-89 (3 Pin) DEVICES

Typical

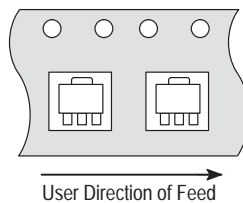

SOT-89 (5 Pin) DEVICES

Typical

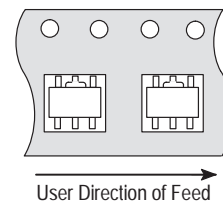

Tape and Reel Configurations (continued)

TO-92 Reel Styles

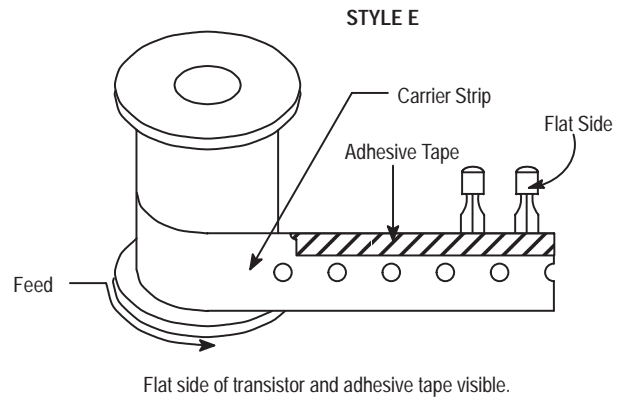
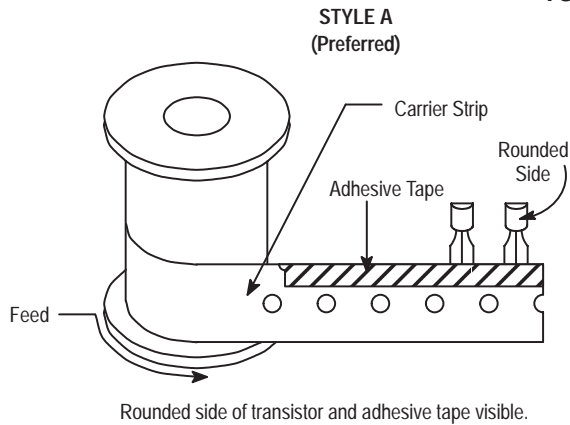

TO-92 Ammo Pack Styles

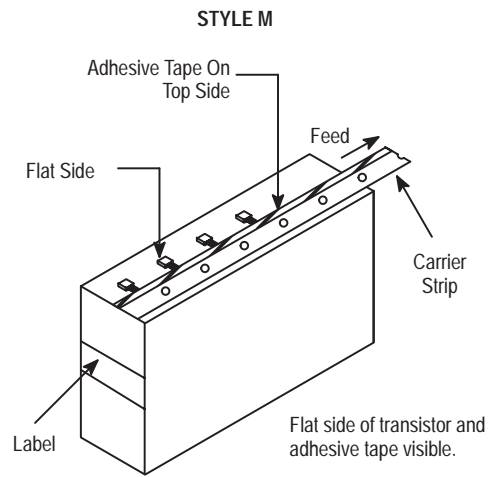
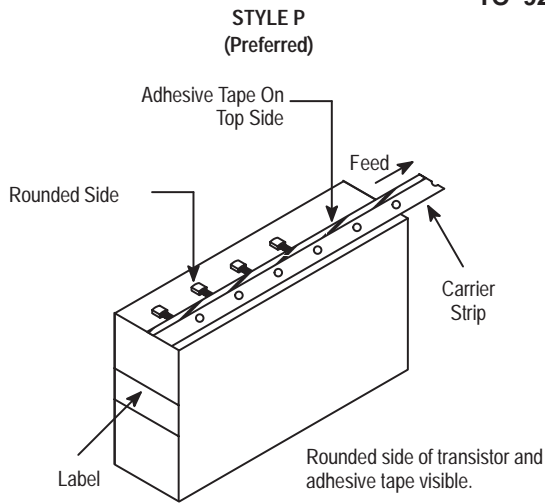

Style P ammo pack is equivalent to Styles A and B of reel pack dependent on feed orientation from box.

Style M ammo pack is equivalent to Style E of reel pack dependent on feed orientation from box.

TO-92 EIA Radial Tape in Fan Fold Box or On Reel

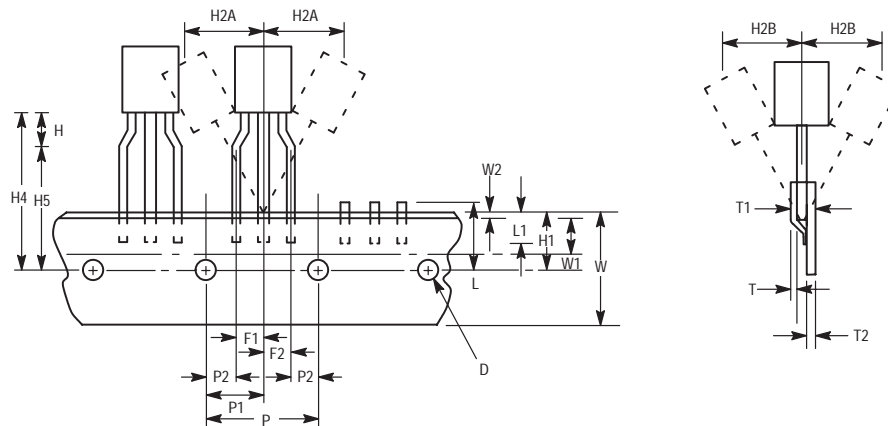

Tape and Reel Information Table

Package	Tape Width (mm)	Devices ⁽¹⁾ per Reel	Reel Size (inch)	Device Suffix
SO-8, SOP-8	12	2,500	13	R2
SO-14	16	2,500	13	R2
SO-16	16	2,500	13	R2
SO-16L, SO-8+8L WIDE	16	1,000	13	R2
SO-20L WIDE	24	1,000	13	R2
SO-24L WIDE	24	1,000	13	R2
SO-28L WIDE	24	1,000	13	R2
SO-28L WIDE	32	1,000	13	R3
Micro-8	12	2,500	13	R2
PLCC-20	16	1,000	13	R2
PLCC-28	24	500	13	R2
PLCC-44	32	500	13	R2
PLCC-52	32	500	13	R2
PLCC-68	44	250	13	R2
PLCC-84	44	250	13	R2
TO-226AA (TO-92) ⁽²⁾	18	2,000	13	RA, RE, RP, or RM (Ammo Pack) only
DPAK	16	2,500	13	RK
D ² PAK	24	800	13	R4
SOT-23 (5 Pin)	8	3,000	7	TR
SOT-89 (3/5 Pin)	12	1,000	7	T1

⁽¹⁾ Minimum order quantity is 1 reel. Distributors/OEM customers may break lots or reels at their option, however broken reels may not be returned.

⁽²⁾ Integrated circuits in TO-226AA packages are available in Styes A and E only, with optional "Ammo Pack" (Suffix RP or RM). The RA and RP configurations are preferred. For ordering information please contact your local Motorola Semiconductor Sales Office.

Analog MPQ Table

Tape/Reel and Ammo Pack

Package Type	Package Code	MPQ
PLCC		
Case 775	0802	1000/reel
Case 776	0804	500/reel
Case 777	0801	500/reel
SOIC		
Case 751	0095	2500/reel
Case 751A	0096	2500/reel
Case 751B	0097	2500/reel
Case 751G	2003	1000/reel
Case 751D	2005	1000/reel
Case 751E	2008	1000/reel
Case 751F	2009	1000/reel
Micro-8		
Case 846A	-	2500/reel
TO-92		
Case 29	0031	2000/reel
Case 29	0031	2000/Ammo Pack
DPAK		
Case 369A	-	2500/reel
D2PAK		
Case 936	-	800/reel
SOT-23 (5 Pin)		
Case 1212	-	3000/reel
SOT-89 (3 Pin)		
Case 1213	-	1000/reel
SOT-89 (5 Pin)		
Case 1214	-	1000/reel

Packaging Information

In Brief . . .

The packaging availability for each device type is indicated on the individual data sheets and the Selector Guide. All of the outline dimensions for the packages are given in this section.

The maximum power consumption an integrated circuit can tolerate at a given operating ambient temperature can be found from the equation:

$$P_{D(TA)} = \frac{T_{J(max)} - T_A}{R_{\theta JA(Typ)}}$$

where:

$P_{D(TA)}$ = *Power Dissipation allowable at a given operating ambient temperature. This must be greater than the sum of the products of the supply voltages and supply currents at the worst case operating condition.*

$T_{J(max)}$ = *Maximum operating Junction Temperature as listed in the Maximum Ratings Section. See individual data sheets for $T_{J(max)}$ information.*

T_A = *Maximum desired operating Ambient Temperature*

$R_{\theta JA(Typ)}$ = *Typical Thermal Resistance Junction-to-Ambient*

Case Outline Dimensions

LP, P, Z SUFFIX
CASE 29-04
 Plastic Package
 (TO-226AA/TO-92)
 ISSUE AD

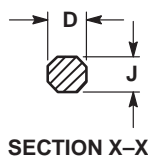
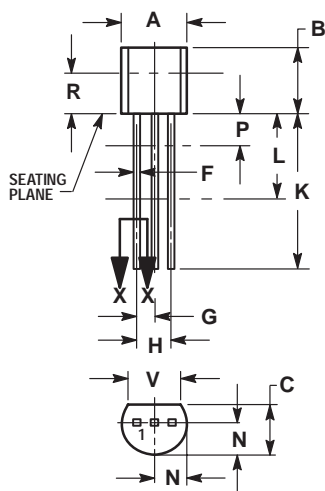

- NOTES:
1. DIMENSIONING AND TOLERANCING PER ANSI Y14.5M, 1982.
 2. CONTROLLING DIMENSION: INCH.
 3. CONTOUR OF PACKAGE BEYOND DIMENSION R IS UNCONTROLLED.
 4. DIMENSION F APPLIES BETWEEN P AND L. DIMENSION D AND J APPLY BETWEEN L AND K MINIMUM. LEAD DIMENSION IS UNCONTROLLED IN P AND BEYOND DIMENSION K MINIMUM.

DIM	INCHES		MILLIMETERS	
	MIN	MAX	MIN	MAX
A	0.175	0.205	4.45	5.20
B	0.170	0.210	4.32	5.33
C	0.125	0.165	3.18	4.19
D	0.016	0.022	0.41	0.55
F	0.016	0.019	0.41	0.48
G	0.045	0.055	1.15	1.39
H	0.095	0.105	2.42	2.66
J	0.015	0.020	0.39	0.50
K	0.500	---	12.70	---
L	0.250	---	6.35	---
N	0.080	0.105	2.04	2.66
P	---	0.100	---	2.54
R	0.115	---	2.93	---
V	0.135	---	3.43	---

KC, T SUFFIX
CASE 221A-06
 Plastic Package
 ISSUE Y

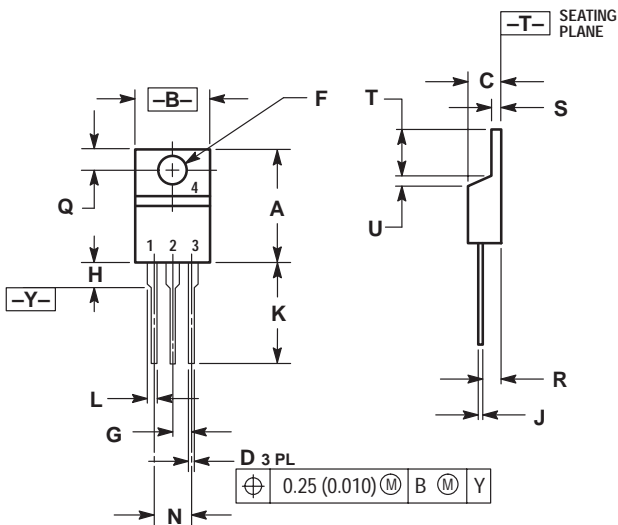
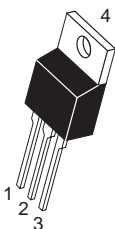

- NOTES:
1. DIMENSIONING AND TOLERANCING PER ANSI Y14.5M, 1982.
 2. CONTROLLING DIMENSION: INCH.

DIM	INCHES		MILLIMETERS	
	MIN	MAX	MIN	MAX
A	0.560	0.625	14.23	15.87
B	0.380	0.420	9.66	10.66
C	0.140	0.190	3.56	4.82
D	0.020	0.045	0.51	1.14
F	0.139	0.155	3.53	3.93
G	0.100 BSC	---	2.54 BSC	---
H	---	0.280	---	7.11
J	0.012	0.045	0.31	1.14
K	0.500	0.580	12.70	14.73
L	0.045	0.070	1.15	1.77
N	0.200 BSC	---	5.08 BSC	---
Q	0.100	0.135	2.54	3.42
R	0.080	0.115	2.04	2.92
S	0.020	0.055	0.51	1.39
T	0.235	0.255	5.97	6.47
U	0.000	0.050	0.00	1.27

TH SUFFIX
CASE 314A-03
 Plastic Package
 ISSUE D

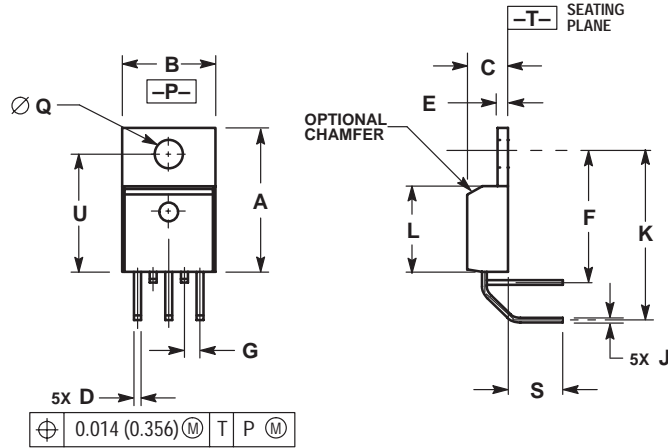
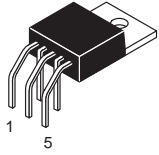

NOTES:

1. DIMENSIONING AND TOLERANCING PER ANSI Y14.5M, 1982.
2. CONTROLLING DIMENSION: INCH.
3. DIMENSION D DOES NOT INCLUDE INTERCONNECT BAR (DAMBAR) PROTRUSION. DIMENSION D INCLUDING PROTRUSION SHALL NOT EXCEED 0.043 (1.092) MAXIMUM.

DIM	INCHES		MILLIMETERS	
	MIN	MAX	MIN	MAX
A	0.572	0.613	14.529	15.570
B	0.390	0.415	9.906	10.541
C	0.170	0.180	4.318	4.572
D	0.025	0.038	0.635	0.965
E	0.048	0.055	1.219	1.397
F	0.570	0.585	14.478	14.859
G	0.067 BSC		1.702 BSC	
J	0.015	0.025	0.381	0.635
K	0.730	0.745	18.542	18.923
L	0.320	0.365	8.128	9.271
Q	0.140	0.153	3.556	3.886
S	0.210	0.260	5.334	6.604
U	0.468	0.505	11.888	12.827

T, TV SUFFIX
CASE 314B-05
 Plastic Package
 ISSUE J

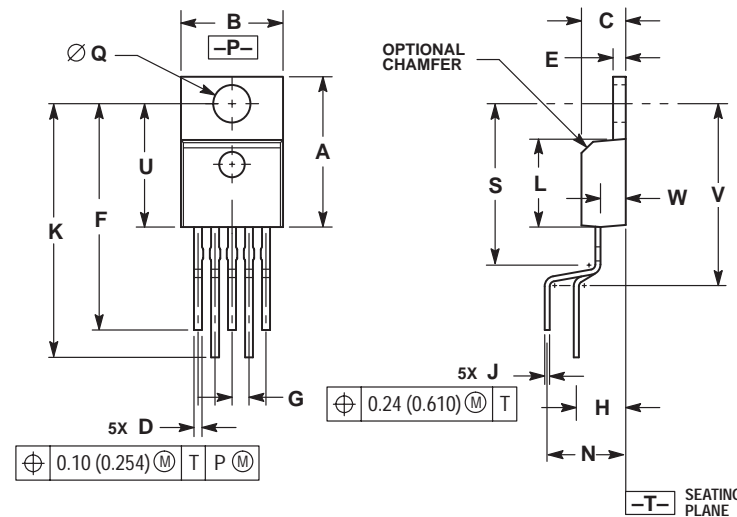
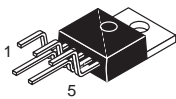

NOTES:

1. DIMENSIONING AND TOLERANCING PER ANSI Y14.5M, 1982.
2. CONTROLLING DIMENSION: INCH.
3. DIMENSION D DOES NOT INCLUDE INTERCONNECT BAR (DAMBAR) PROTRUSION. DIMENSION D INCLUDING PROTRUSION SHALL NOT EXCEED 0.043 (1.092) MAXIMUM.

DIM	INCHES		MILLIMETERS	
	MIN	MAX	MIN	MAX
A	0.572	0.613	14.529	15.570
B	0.390	0.415	9.906	10.541
C	0.170	0.180	4.318	4.572
D	0.025	0.038	0.635	0.965
E	0.048	0.055	1.219	1.397
F	0.850	0.935	21.590	23.749
G	0.067 BSC		1.702 BSC	
H	0.166 BSC		4.216 BSC	
J	0.015	0.025	0.381	0.635
K	0.900	1.100	22.860	27.940
L	0.320	0.365	8.128	9.271
N	0.320 BSC		8.128 BSC	
Q	0.140	0.153	3.556	3.886
S	---	0.620	---	15.748
U	0.468	0.505	11.888	12.827
V	---	0.735	---	18.669
W	0.090	0.110	2.286	2.794

T SUFFIX
CASE 314C-01
 Plastic Package
 ISSUE A

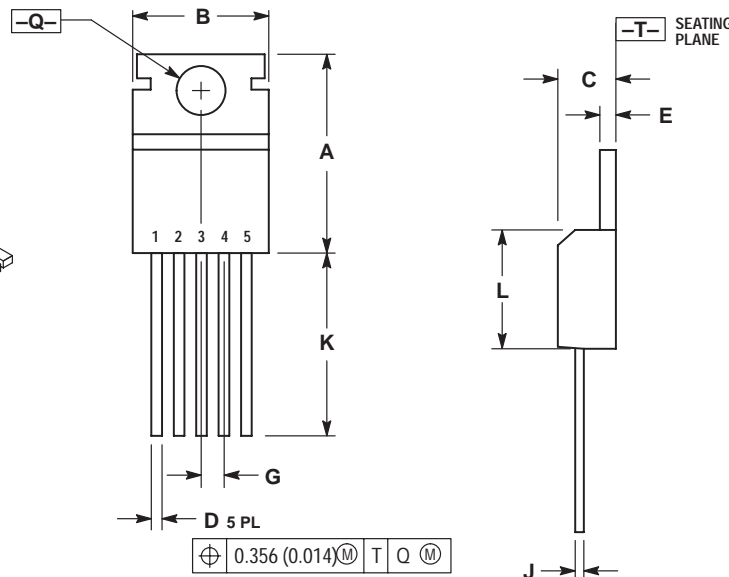
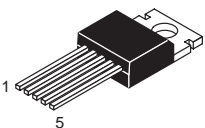

NOTES:

1. DIMENSIONING AND TOLERANCING PER ANSI Y14.5M, 1982.
2. CONTROLLING DIMENSION: INCH.
3. DIMENSION D DOES NOT INCLUDE INTERCONNECT BAR (DAMBAR) PROTRUSION. DIMENSION D INCLUDING PROTRUSION SHALL NOT EXCEED 10.92 (0.043) MAXIMUM.

DIM	INCHES		MILLIMETERS	
	MIN	MAX	MIN	MAX
A	0.610	0.625	15.59	15.88
B	0.380	0.420	9.65	10.67
C	0.160	0.190	4.06	4.83
D	0.020	0.040	0.51	1.02
E	0.035	0.055	0.89	1.40
G	0.067 BSC		1.702 BSC	
J	0.015	0.025	0.38	0.64
K	0.500	---	12.70	---
L	0.355	0.370	9.02	9.40
Q	0.139	0.147	3.53	3.73

T, T1 SUFFIX
CASE 314D-03
 Plastic Package
 ISSUE D

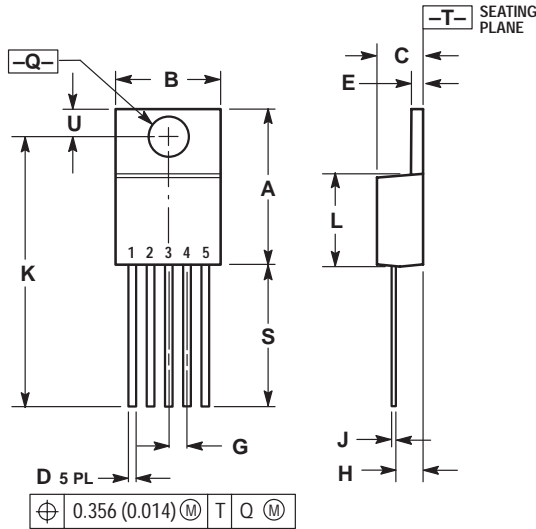
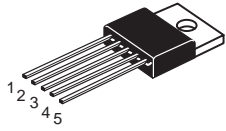

- NOTES:
1. DIMENSIONING AND TOLERANCING PER ANSI Y14.5M, 1982.
 2. CONTROLLING DIMENSION: INCH.
 3. DIMENSION D DOES NOT INCLUDE INTERCONNECT BAR (DAMBAR) PROTRUSION. DIMENSION D INCLUDING PROTRUSION SHALL NOT EXCEED 10.92 (0.043) MAXIMUM.

DIM	INCHES		MILLIMETERS	
	MIN	MAX	MIN	MAX
A	0.572	0.613	14.529	15.570
B	0.390	0.415	9.906	10.541
C	0.170	0.180	4.318	4.572
D	0.025	0.038	0.635	0.965
E	0.048	0.055	1.219	1.397
G	0.067 BSC		1.702 BSC	
H	0.087	0.112	2.210	2.845
J	0.015	0.025	0.381	0.635
K	1.020	1.065	25.908	27.051
L	0.320	0.365	8.128	9.271
Q	0.140	0.153	3.556	3.886
U	0.105	0.117	2.667	2.972
S	0.543	0.582	13.792	14.783

DT-1 SUFFIX
CASE 369-07
 Plastic Package (DPAK)
 ISSUE K

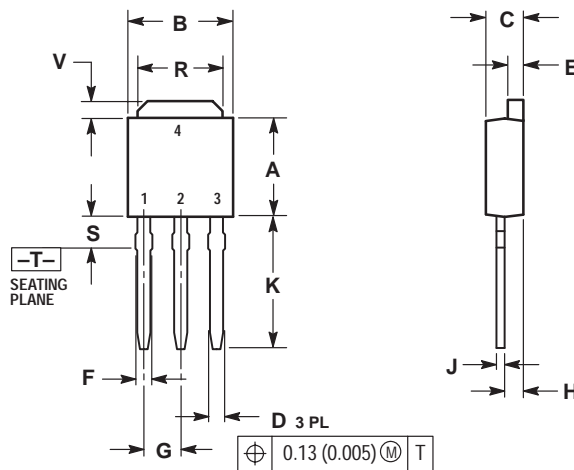
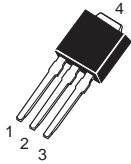

- NOTES:
1. DIMENSIONING AND TOLERANCING PER ANSI Y14.5M, 1982.
 2. CONTROLLING DIMENSION: INCH.

DIM	INCHES		MILLIMETERS	
	MIN	MAX	MIN	MAX
A	0.235	0.250	5.97	6.35
B	0.250	0.265	6.35	6.73
C	0.086	0.094	2.19	2.38
D	0.027	0.035	0.69	0.88
E	0.033	0.040	0.84	1.01
F	0.037	0.047	0.94	1.19
G	0.090 BSC		2.29 BSC	
H	0.034	0.040	0.87	1.01
J	0.018	0.023	0.46	0.58
K	0.350	0.380	8.89	9.65
R	0.175	0.215	4.45	5.46
S	0.050	0.090	1.27	2.28
V	0.030	0.050	0.77	1.27

DT SUFFIX
CASE 369A-13
 Plastic Package (DPAK)
 ISSUE Y

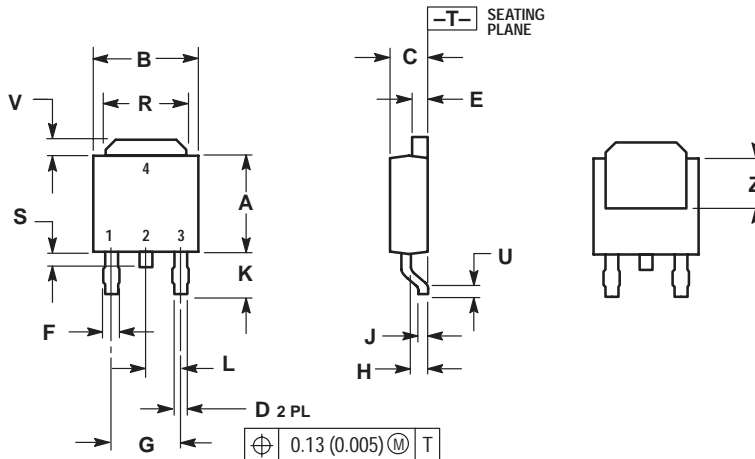
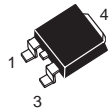

- NOTES:
1. DIMENSIONING AND TOLERANCING PER ANSI Y14.5M, 1982.
 2. CONTROLLING DIMENSION: INCH.

DIM	INCHES		MILLIMETERS	
	MIN	MAX	MIN	MAX
A	0.235	0.250	5.97	6.35
B	0.250	0.265	6.35	6.73
C	0.086	0.094	2.19	2.38
D	0.027	0.035	0.69	0.88
E	0.033	0.040	0.84	1.01
F	0.037	0.047	0.94	1.19
G	0.180 BSC		4.58 BSC	
H	0.034	0.040	0.87	1.01
J	0.018	0.023	0.46	0.58
K	0.102	0.114	2.60	2.89
L	0.090 BSC		2.29 BSC	
R	0.175	0.215	4.45	5.46
S	0.020	0.050	0.51	1.27
U	0.020	---	0.51	---
V	0.030	0.050	0.77	1.27
Z	0.138	---	3.51	---

DP1, N, P, P1 SUFFIX
CASE 626-05
 Plastic Package
 ISSUE K

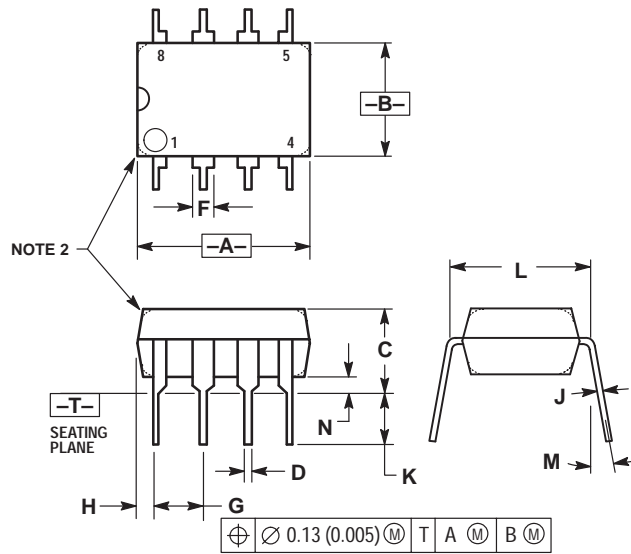
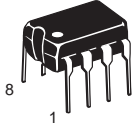

- NOTES:
1. DIMENSION L TO CENTER OF LEAD WHEN FORMED PARALLEL.
 2. PACKAGE CONTOUR OPTIONAL (ROUND OR SQUARE CORNERS).
 3. DIMENSIONING AND TOLERANCING PER ANSI Y14.5M, 1982.

DIM	MILLIMETERS		INCHES	
	MIN	MAX	MIN	MAX
A	9.40	10.16	0.370	0.400
B	6.10	6.60	0.240	0.260
C	3.94	4.45	0.155	0.175
D	0.38	0.51	0.015	0.020
F	1.02	1.78	0.040	0.070
G	2.54 BSC		0.100 BSC	
H	0.76	1.27	0.030	0.050
J	0.20	0.30	0.008	0.012
K	2.92	3.43	0.115	0.135
L	7.62 BSC		0.300 BSC	
M	— 10°		— 10°	
N	0.76	1.01	0.030	0.040

N, P, N-14, P2 SUFFIX
CASE 646-06
 Plastic Package
 ISSUE L

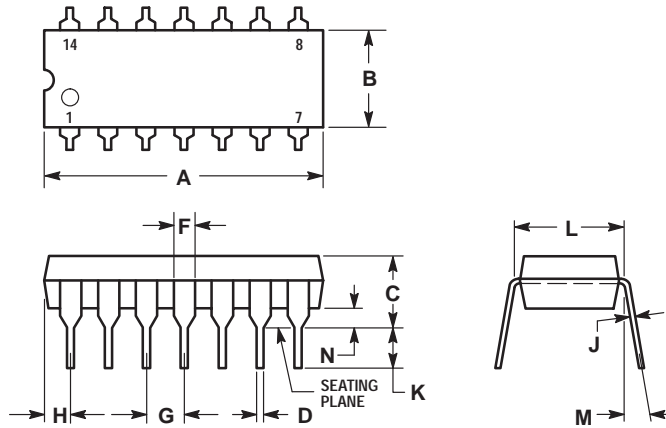
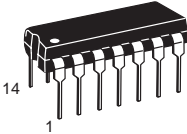

- NOTES:
1. LEADS WITHIN 0.13 (0.005) RADIUS OF TRUE POSITION AT SEATING PLANE AT MAXIMUM MATERIAL CONDITION.
 2. DIMENSION L TO CENTER OF LEADS WHEN FORMED PARALLEL.
 3. DIMENSION B DOES NOT INCLUDE MOLD FLASH.
 4. ROUNDED CORNERS OPTIONAL.

DIM	INCHES		MILLIMETERS	
	MIN	MAX	MIN	MAX
A	0.715	0.770	18.16	19.56
B	0.240	0.260	6.10	6.60
C	0.145	0.185	3.69	4.69
D	0.015	0.021	0.38	0.53
F	0.040	0.070	1.02	1.78
G	0.100 BSC		2.54 BSC	
H	0.052	0.095	1.32	2.41
J	0.008	0.015	0.20	0.38
K	0.115	0.135	2.92	3.43
L	0.300 BSC		7.62 BSC	
M	0° 10°		0° 10°	
N	0.015	0.039	0.39	1.01

DP2, N, P, PC SUFFIX
CASE 648-08
 Plastic Package
 ISSUE R

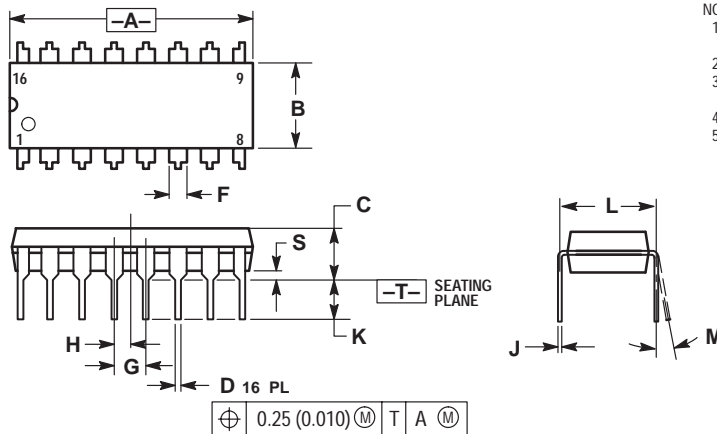
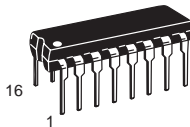

- NOTES:
1. DIMENSIONING AND TOLERANCING PER ANSI Y14.5M, 1982.
 2. CONTROLLING DIMENSION: INCH.
 3. DIMENSION L TO CENTER OF LEADS WHEN FORMED PARALLEL.
 4. DIMENSION B DOES NOT INCLUDE MOLD FLASH.
 5. ROUNDED CORNERS OPTIONAL.

DIM	INCHES		MILLIMETERS	
	MIN	MAX	MIN	MAX
A	0.740	0.770	18.80	19.55
B	0.250	0.270	6.35	6.85
C	0.145	0.175	3.69	4.44
D	0.015	0.021	0.39	0.53
F	0.040	0.70	1.02	1.77
G	0.100 BSC		2.54 BSC	
H	0.050 BSC		1.27 BSC	
J	0.008	0.015	0.21	0.38
K	0.110	0.130	2.80	3.30
L	0.295	0.305	7.50	7.74
M	0° 10°		0° 10°	
S	0.020	0.040	0.51	1.01

B, P, P2, V SUFFIX
CASE 648C-03
 Plastic Package
 (DIP-16)
 ISSUE C

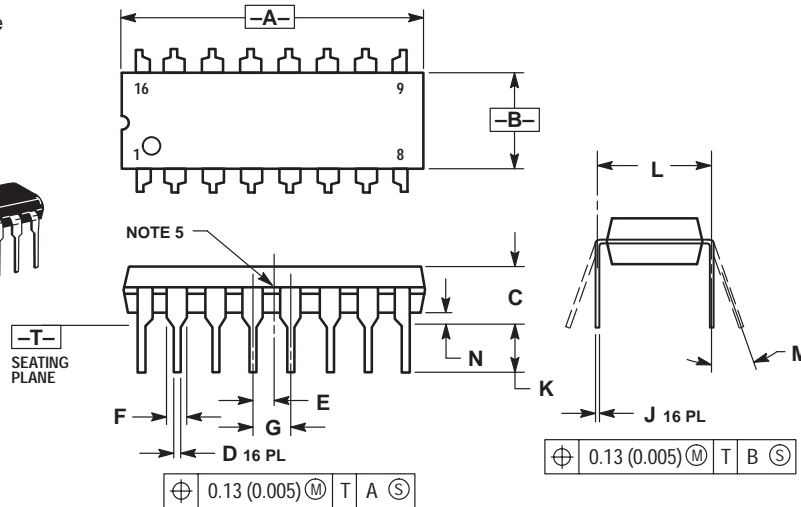
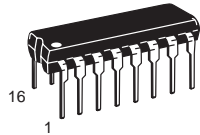

- NOTES:
1. DIMENSIONING AND TOLERANCING PER ANSI Y14.5M, 1982.
 2. CONTROLLING DIMENSION: INCH.
 3. DIMENSION L TO CENTER OF LEADS WHEN FORMED PARALLEL.
 4. DIMENSION B DOES NOT INCLUDE MOLD FLASH.
 5. INTERNAL LEAD CONNECTION BETWEEN 4 AND 5, 12 AND 13.

DIM	INCHES		MILLIMETERS	
	MIN	MAX	MIN	MAX
A	0.740	0.840	18.80	21.34
B	0.240	0.260	6.10	6.60
C	0.145	0.185	3.69	4.69
D	0.015	0.021	0.38	0.53
E	0.050 BSC			
F	0.040	0.70	1.02	1.78
G	0.100 BSC			
J	0.008	0.015	0.20	0.38
K	0.115	0.135	2.92	3.43
L	0.300 BSC			
M	0°	10°	0°	10°
N	0.015	0.040	0.39	1.01

P SUFFIX
CASE 648E-01
 Plastic Package
 (DIP-16)
 ISSUE O

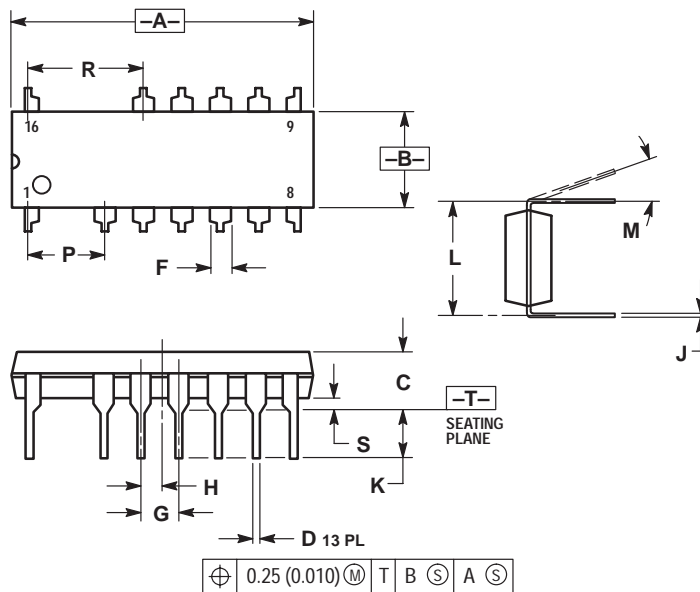
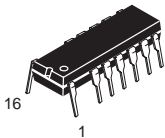

- NOTES:
1. DIMENSIONING AND TOLERANCING PER ANSI Y14.5M, 1982.
 2. CONTROLLING DIMENSION: INCH.
 3. DIMENSION L TO CENTER OF LEADS WHEN FORMED PARALLEL.
 4. DIMENSION A AND B DOES NOT INCLUDE MOLD PROTRUSION.
 5. MOLD FLASH OR PROTRUSIONS SHALL NOT EXCEED 0.25 (0.010).
 6. ROUNDED CORNER OPTIONAL.

DIM	INCHES		MILLIMETERS	
	MIN	MAX	MIN	MAX
A	0.740	0.760	18.80	19.30
B	0.245	0.260	6.23	6.60
C	0.145	0.175	3.69	4.44
D	0.015	0.021	0.39	0.53
F	0.050	0.070	1.27	1.77
G	0.100 BSC			
H	0.050 BSC			
J	0.008	0.015	0.21	0.38
K	0.120	0.140	3.05	3.55
L	0.295	0.305	7.50	7.74
M	0°	10°	0°	10°
P	0.200 BSC			
R	0.300 BSC			
S	0.015	0.035	0.39	0.88

P SUFFIX
CASE 649-03
 Plastic Package
 ISSUE D

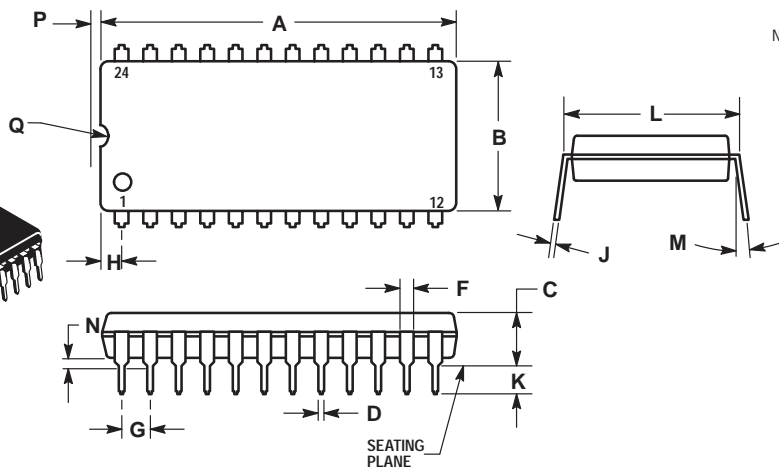
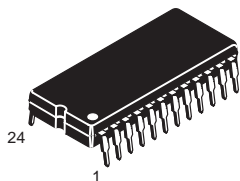

- NOTES:
1. LEADS WITHIN 0.13 (0.005) RADIUS OF TRUE POSITION AT SEATING PLANE AT MAXIMUM MATERIAL CONDITION.
 2. DIMENSION L TO CENTER OF LEADS WHEN FORMED PARALLEL.

DIM	MILLIMETERS		INCHES	
	MIN	MAX	MIN	MAX
A	31.50	32.13	1.240	1.265
B	13.21	13.72	0.520	0.540
C	4.70	5.21	0.185	0.205
D	0.38	0.51	0.015	0.020
F	1.02	1.52	0.040	0.060
G	2.54 BSC			
H	1.65	2.16	0.065	0.085
J	0.20	0.30	0.008	0.012
K	2.92	3.43	0.115	0.135
L	14.99	15.49	0.590	0.610
M	---	10	---	10°
N	0.51	1.02	0.020	0.040
P	0.13	0.38	0.005	0.015
Q	0.51	0.76	0.020	0.030

A, B, N, P SUFFIX
CASE 707-02
 Plastic Package
 ISSUE C

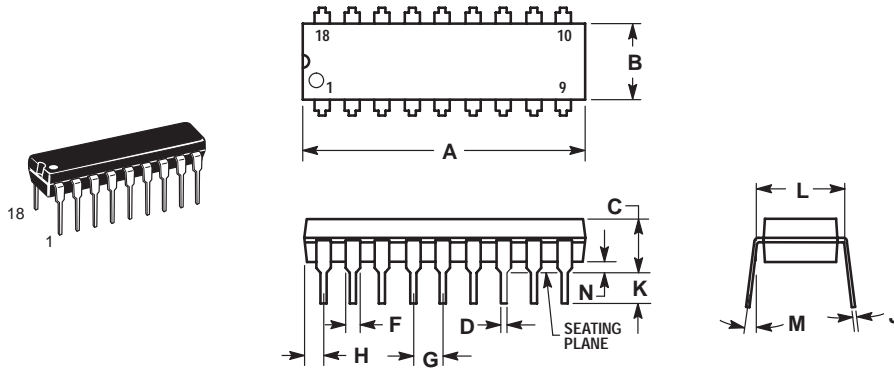

- NOTES:
1. POSITIONAL TOLERANCE OF LEADS (D), SHALL BE WITHIN 0.25 (0.010) AT MAXIMUM MATERIAL CONDITION, IN RELATION TO SEATING PLANE AND EACH OTHER.
 2. DIMENSION L TO CENTER OF LEADS WHEN FORMED PARALLEL.
 3. DIMENSION B DOES NOT INCLUDE MOLD FLASH.

DIM	MILLIMETERS		INCHES	
	MIN	MAX	MIN	MAX
A	22.22	23.24	0.875	0.915
B	6.10	6.60	0.240	0.260
C	3.56	4.57	0.140	0.180
D	0.36	0.56	0.014	0.022
F	1.27	1.78	0.050	0.070
G	2.54 BSC		0.100 BSC	
H	1.02	1.52	0.040	0.060
J	0.20	0.30	0.008	0.012
K	2.92	3.43	0.115	0.135
L	7.62 BSC		0.300 BSC	
M	0°	15°	0°	15°
N	0.51	1.02	0.020	0.040

P SUFFIX
CASE 710-02
 Plastic Package
 ISSUE B

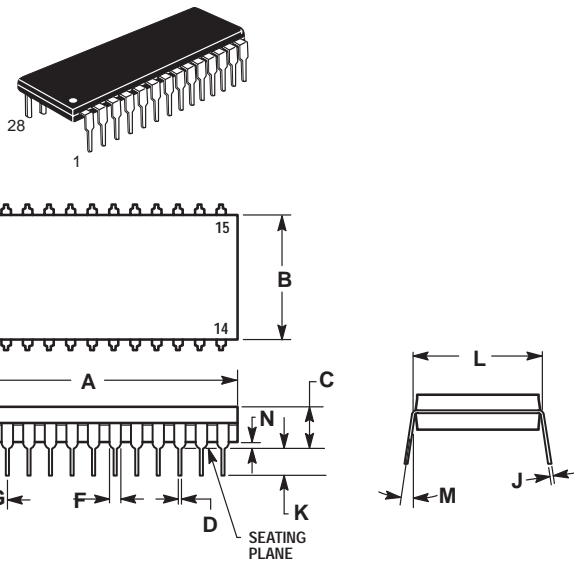

- NOTES:
1. POSITIONAL TOLERANCE OF LEADS (D), SHALL BE WITHIN 0.25 (0.010) AT MAXIMUM MATERIAL CONDITION, IN RELATION TO SEATING PLANE AND EACH OTHER.
 2. DIMENSION L TO CENTER OF LEADS WHEN FORMED PARALLEL.
 3. DIMENSION B DOES NOT INCLUDE MOLD FLASH.

DIM	MILLIMETERS		INCHES	
	MIN	MAX	MIN	MAX
A	36.45	37.21	1.435	1.465
B	13.72	14.22	0.540	0.560
C	3.94	5.08	0.155	0.200
D	0.36	0.56	0.014	0.022
F	1.02	1.52	0.040	0.060
G	2.54 BSC		0.100 BSC	
H	1.65	2.16	0.065	0.085
J	0.20	0.38	0.008	0.015
K	2.92	3.43	0.115	0.135
L	15.24 BSC		0.600 BSC	
M	0°	15°	0°	15°
N	0.51	1.02	0.020	0.040

P SUFFIX
CASE 711-03
 Plastic Package
 ISSUE C

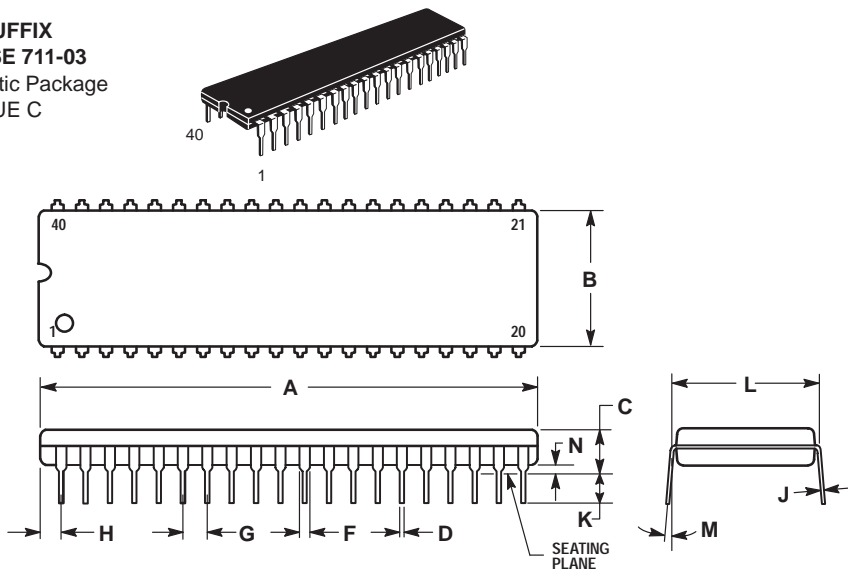

- NOTES:
1. POSITIONAL TOLERANCE OF LEADS (D), SHALL BE WITHIN 0.25 (0.010) AT MAXIMUM MATERIAL CONDITION, IN RELATION TO SEATING PLANE AND EACH OTHER.
 2. DIMENSION L TO CENTER OF LEADS WHEN FORMED PARALLEL.
 3. DIMENSION B DOES NOT INCLUDE MOLD FLASH.

DIM	MILLIMETERS		INCHES	
	MIN	MAX	MIN	MAX
A	51.69	52.45	2.035	2.065
B	13.72	14.22	0.540	0.560
C	3.94	5.08	0.155	0.200
D	0.36	0.56	0.014	0.022
F	1.02	1.52	0.040	0.060
G	2.54 BSC		0.100 BSC	
H	1.65	2.16	0.065	0.085
J	0.20	0.38	0.008	0.015
K	2.92	3.43	0.115	0.135
L	15.24 BSC		0.600 BSC	
M	0°	15°	0°	15°
N	0.51	1.02	0.020	0.040

F, P, P-3 SUFFIX
CASE 724-03
 Plastic Package
 (NDIP-24)
 ISSUE D

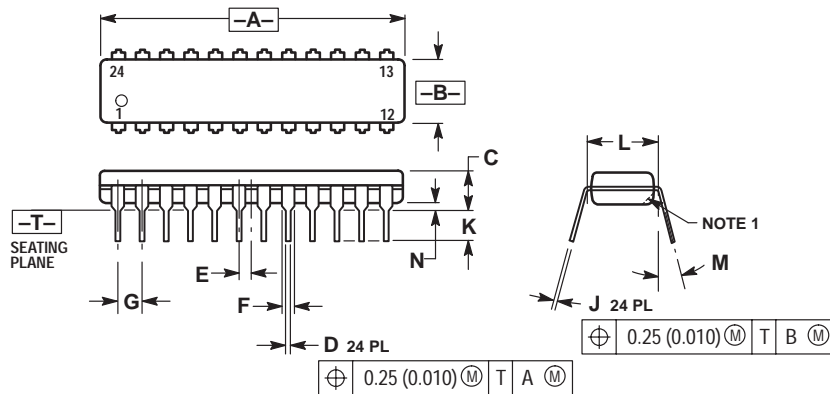
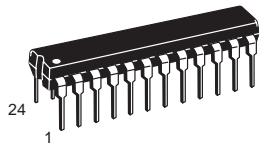

- NOTES:
1. CHAMFERED CONTOUR OPTIONAL.
 2. DIMENSION L TO CENTER OF LEADS WHEN FORMED PARALLEL.
 3. DIMENSIONING AND TOLERANCING PER ANSI Y14.5M, 1982.
 4. CONTROLLING DIMENSION: INCH.

DIM	INCHES		MILLIMETERS	
	MIN	MAX	MIN	MAX
A	1.230	1.265	31.25	32.13
B	0.250	0.270	6.35	6.85
C	0.145	0.175	3.69	4.44
D	0.015	0.020	0.38	0.51
E	0.050 BSC		1.27 BSC	
F	0.040	0.060	1.02	1.52
G	0.100 BSC		2.54 BSC	
J	0.007	0.012	0.18	0.30
K	0.110	0.140	2.80	3.55
L	0.300 BSC		7.62 BSC	
M	0°	15°	0°	15°
N	0.020	0.040	0.51	1.01

H, P, DP SUFFIX
CASE 738-03
 Plastic Package
 ISSUE E

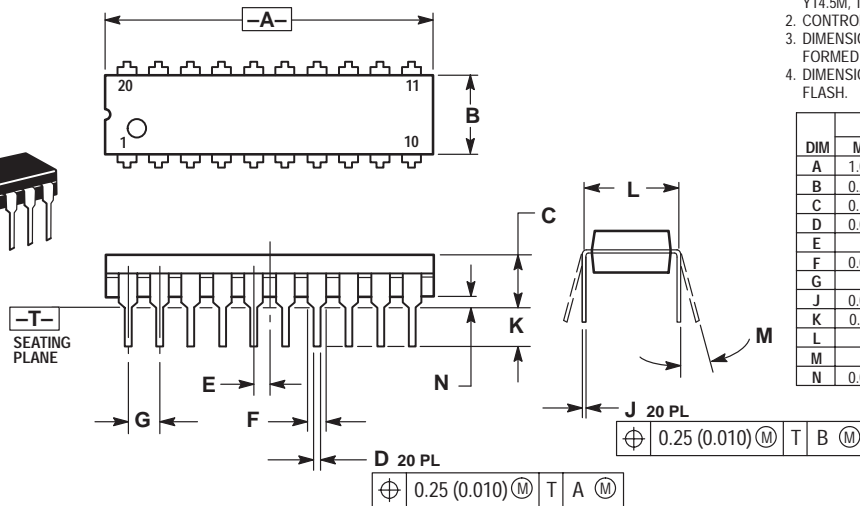
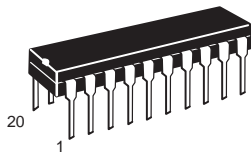

- NOTES:
1. DIMENSIONING AND TOLERANCING PER ANSI Y14.5M, 1982.
 2. CONTROLLING DIMENSION: INCH.
 3. DIMENSION L TO CENTER OF LEAD WHEN FORMED PARALLEL.
 4. DIMENSION B DOES NOT INCLUDE MOLD FLASH.

DIM	INCHES		MILLIMETERS	
	MIN	MAX	MIN	MAX
A	1.010	1.070	25.66	27.17
B	0.240	0.260	6.10	6.60
C	0.150	0.180	3.81	4.57
D	0.015	0.022	0.39	0.55
E	0.050 BSC		1.27 BSC	
F	0.050	0.070	1.27	1.77
G	0.100 BSC		2.54 BSC	
J	0.008	0.015	0.21	0.38
K	0.110	0.140	2.80	3.55
L	0.300 BSC		7.62 BSC	
M	0°	15°	0°	15°
N	0.020	0.040	0.51	1.01

D, D1, D2 SUFFIX
CASE 751-05
 Plastic Package
 (SO-8, SOP-8)
 ISSUE R

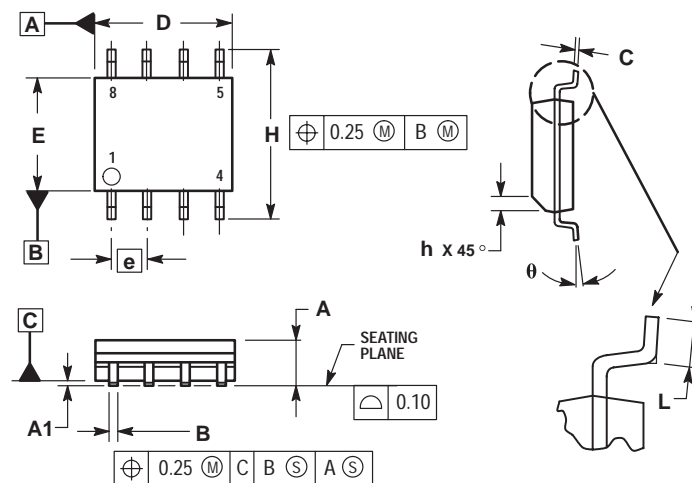

- NOTES:
1. DIMENSIONING AND TOLERANCING PER ASME Y14.5M, 1994.
 2. DIMENSIONS ARE IN MILLIMETERS.
 3. DIMENSION D AND E DO NOT INCLUDE MOLD PROTRUSION.
 4. MAXIMUM MOLD PROTRUSION 0.15 PER SIDE.
 5. DIMENSION B DOES NOT INCLUDE MOLD PROTRUSION. ALLOWABLE DAMBAR PROTRUSION SHALL BE 0.127 TOTAL IN EXCESS OF THE B DIMENSION AT MAXIMUM MATERIAL CONDITION.

DIM	MILLIMETERS	
	MIN	MAX
A	1.35	1.75
A1	0.10	0.25
B	0.35	0.49
C	0.18	0.25
D	4.80	5.00
E	3.80	4.00
e	1.27 BSC	
H	5.80	6.20
h	0.25	0.50
L	0.40	1.25
θ	0°	7°

D SUFFIX
CASE 751A-03
 Plastic Package
 (SO-14)
 ISSUE F

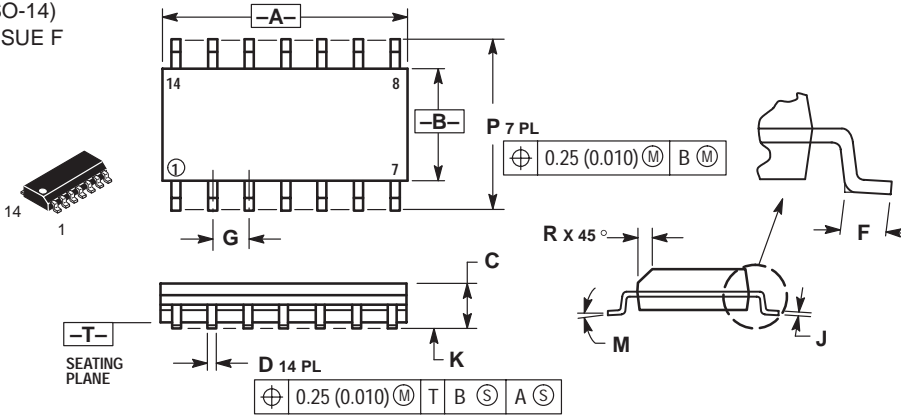

- NOTES:
1. DIMENSIONING AND TOLERANCING PER ANSI Y14.5M, 1982.
 2. CONTROLLING DIMENSION: MILLIMETER.
 3. DIMENSIONS A AND B DO NOT INCLUDE MOLD PROTRUSION.
 4. MAXIMUM MOLD PROTRUSION 0.15 (0.006) PER SIDE.
 5. DIMENSION D DOES NOT INCLUDE DAMBAR PROTRUSION. ALLOWABLE DAMBAR PROTRUSION SHALL BE 0.127 (0.005) TOTAL IN EXCESS OF THE D DIMENSION AT MAXIMUM MATERIAL CONDITION.

DIM	MILLIMETERS		INCHES	
	MIN	MAX	MIN	MAX
A	8.55	8.75	0.337	0.344
B	3.80	4.00	0.150	0.157
C	1.35	1.75	0.054	0.068
D	0.35	0.49	0.014	0.019
F	0.40	1.25	0.016	0.049
G	1.27 BSC		0.050 BSC	
J	0.19	0.25	0.008	0.009
K	0.10	0.25	0.004	0.009
M	0°	7°	0°	7°
P	5.80	6.20	0.228	0.244
R	0.25	0.50	0.010	0.019

D SUFFIX
CASE 751B-05
 Plastic Package
 (SO-16)
 ISSUE J

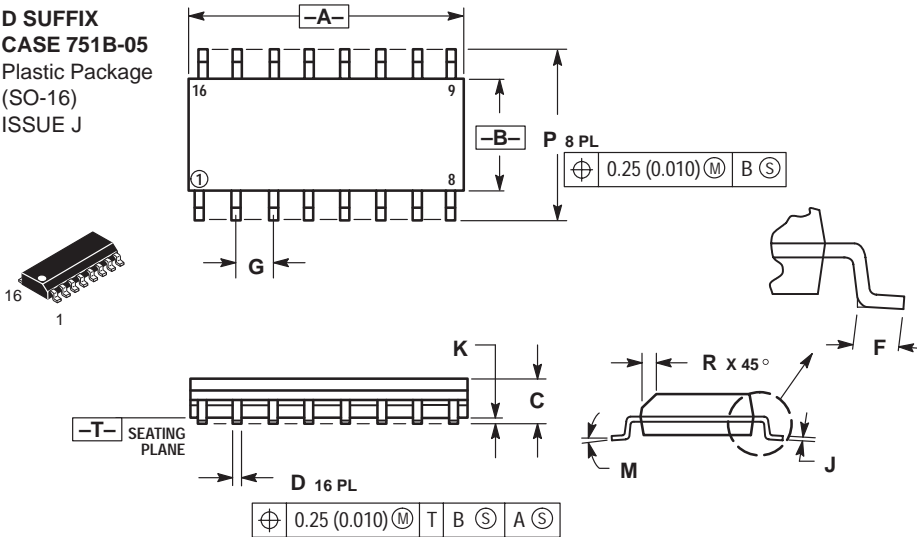

- NOTES:
1. DIMENSIONING AND TOLERANCING PER ANSI Y14.5M, 1982.
 2. CONTROLLING DIMENSION: MILLIMETER.
 3. DIMENSIONS A AND B DO NOT INCLUDE MOLD PROTRUSION.
 4. MAXIMUM MOLD PROTRUSION 0.15 (0.006) PER SIDE.
 5. DIMENSION D DOES NOT INCLUDE DAMBAR PROTRUSION. ALLOWABLE DAMBAR PROTRUSION SHALL BE 0.127 (0.005) TOTAL IN EXCESS OF THE D DIMENSION AT MAXIMUM MATERIAL CONDITION.

DIM	MILLIMETERS		INCHES	
	MIN	MAX	MIN	MAX
A	9.80	10.00	0.386	0.393
B	3.80	4.00	0.150	0.157
C	1.35	1.75	0.054	0.068
D	0.35	0.49	0.014	0.019
F	0.40	1.25	0.016	0.049
G	1.27 BSC		0.050 BSC	
J	0.19	0.25	0.008	0.009
K	0.10	0.25	0.004	0.009
M	0°	7°	0°	7°
P	5.80	6.20	0.229	0.244
R	0.25	0.50	0.010	0.019

DW, FP SUFFIX
CASE 751D-04
 Plastic Package
 (SO-20L, SO-20)
 ISSUE E

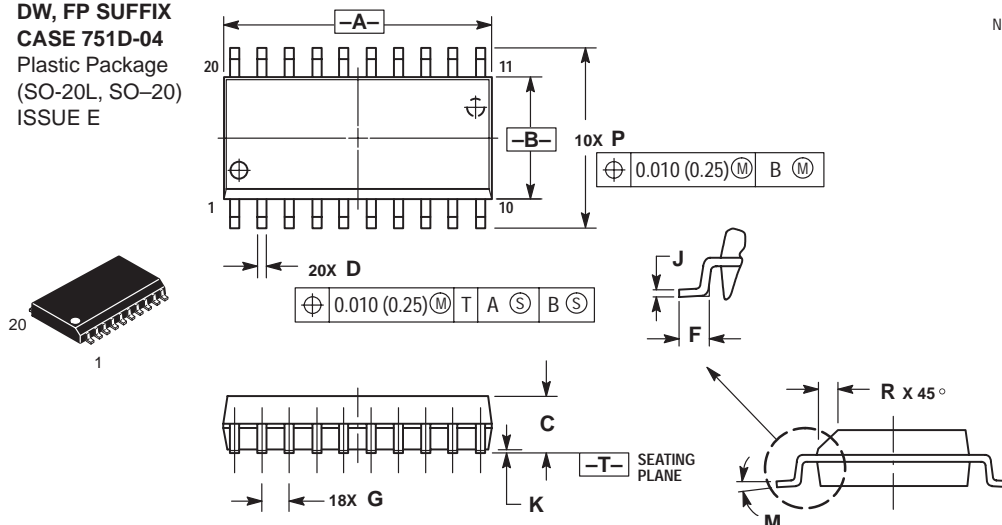

- NOTES:
1. DIMENSIONING AND TOLERANCING PER ANSI Y14.5M, 1982.
 2. CONTROLLING DIMENSION: MILLIMETER.
 3. DIMENSIONS A AND B DO NOT INCLUDE MOLD PROTRUSION.
 4. MAXIMUM MOLD PROTRUSION 0.150 (0.006) PER SIDE.
 5. DIMENSION D DOES NOT INCLUDE DAMBAR PROTRUSION. ALLOWABLE DAMBAR PROTRUSION SHALL BE 0.13 (0.005) TOTAL IN EXCESS OF D DIMENSION AT MAXIMUM MATERIAL CONDITION.

DIM	MILLIMETERS		INCHES	
	MIN	MAX	MIN	MAX
A	12.65	12.95	0.499	0.510
B	7.40	7.60	0.292	0.299
C	2.35	2.65	0.093	0.104
D	0.35	0.49	0.014	0.019
F	0.50	0.90	0.020	0.035
G	1.27 BSC		0.050 BSC	
J	0.25	0.32	0.010	0.012
K	0.10	0.25	0.004	0.009
M	0°	7°	0°	7°
P	10.05	10.55	0.395	0.415
R	0.25	0.75	0.010	0.029

DW SUFFIX
CASE 751E-04
 Plastic Package
 (SO-24L,
 SOP (16+4+4)L)
 ISSUE E

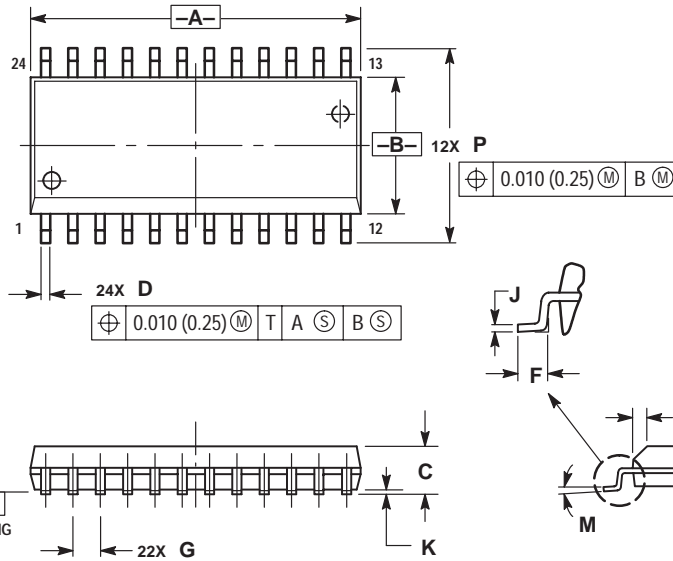
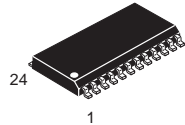

- NOTES:
1. DIMENSIONING AND TOLERANCING PER ANSI Y14.5M, 1982.
 2. CONTROLLING DIMENSION: MILLIMETER.
 3. DIMENSIONS A AND B DO NOT INCLUDE MOLD PROTRUSION.
 4. MAXIMUM MOLD PROTRUSION 0.15 (0.006) PER SIDE.
 5. DIMENSION D DOES NOT INCLUDE DAMBAR PROTRUSION. ALLOWABLE DAMBAR PROTRUSION SHALL BE 0.13 (0.005) TOTAL IN EXCESS OF D DIMENSION AT MAXIMUM MATERIAL CONDITION.

DIM	MILLIMETERS		INCHES	
	MIN	MAX	MIN	MAX
A	15.25	15.54	0.601	0.612
B	7.40	7.60	0.292	0.299
C	2.35	2.65	0.093	0.104
D	0.35	0.49	0.014	0.019
F	0.41	0.90	0.016	0.035
G	1.27 BSC		0.050 BSC	
J	0.23	0.32	0.009	0.013
K	0.13	0.29	0.005	0.011
M	0°	8°	0°	8°
P	10.05	10.55	0.395	0.415
R	0.25	0.75	0.010	0.029

DW SUFFIX
CASE 751F-04
 Plastic Package
 (SO-28L, SOIC-28)
 ISSUE E

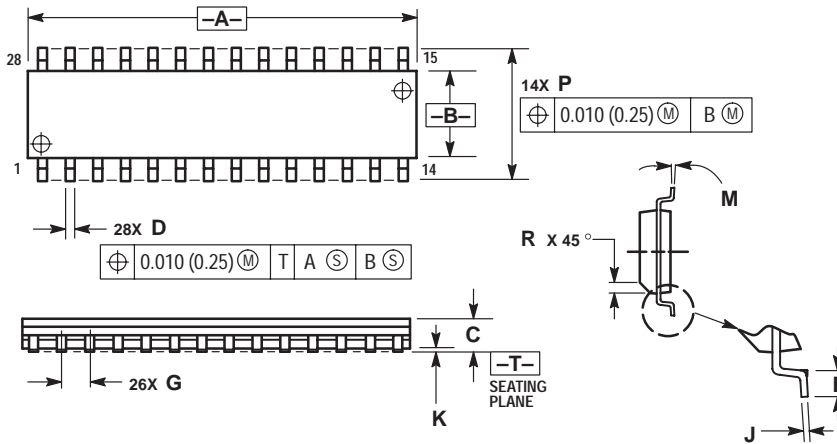
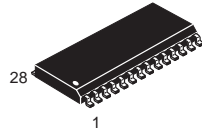

- NOTES:
1. DIMENSIONING AND TOLERANCING PER ANSI Y14.5M, 1982.
 2. CONTROLLING DIMENSION: MILLIMETER.
 3. DIMENSION A AND B DO NOT INCLUDE MOLD PROTRUSION.
 4. MAXIMUM MOLD PROTRUSION 0.15 (0.006) PER SIDE.
 5. DIMENSION D DOES NOT INCLUDE DAMBAR PROTRUSION. ALLOWABLE DAMBAR PROTRUSION SHALL BE 0.13 (0.005) TOTAL IN EXCESS OF D DIMENSION AT MAXIMUM MATERIAL CONDITION.

DIM	MILLIMETERS		INCHES	
	MIN	MAX	MIN	MAX
A	17.80	18.05	0.701	0.711
B	7.40	7.60	0.292	0.299
C	2.35	2.65	0.093	0.104
D	0.35	0.49	0.014	0.019
F	0.41	0.90	0.016	0.035
G	1.27 BSC		0.050 BSC	
J	0.23	0.32	0.009	0.013
K	0.13	0.29	0.005	0.011
M	0°	8°	0°	8°
P	10.01	10.55	0.395	0.415
R	0.25	0.75	0.010	0.029

DW SUFFIX
CASE 751G-02
 Plastic Package
 (SO-16L, SOP-16L,
 SOP-8+8L)
 ISSUE A

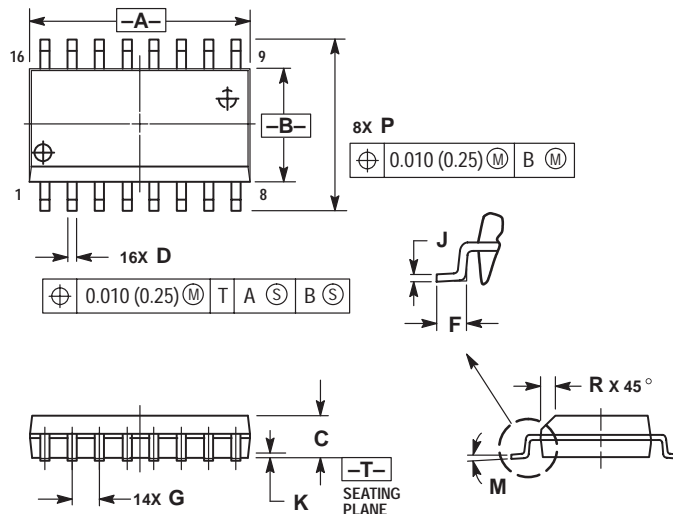
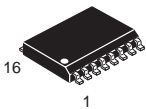

- NOTES:
1. DIMENSIONING AND TOLERANCING PER ANSI Y14.5M, 1982.
 2. CONTROLLING DIMENSION: MILLIMETER.
 3. DIMENSIONS A AND B DO NOT INCLUDE MOLD PROTRUSION.
 4. MAXIMUM MOLD PROTRUSION 0.15 (0.006) PER SIDE.
 5. DIMENSION D DOES NOT INCLUDE DAMBAR PROTRUSION. ALLOWABLE DAMBAR PROTRUSION SHALL BE 0.13 (0.005) TOTAL IN EXCESS OF D DIMENSION AT MAXIMUM MATERIAL CONDITION.

DIM	MILLIMETERS		INCHES	
	MIN	MAX	MIN	MAX
A	10.15	10.45	0.400	0.411
B	7.40	7.60	0.292	0.299
C	2.35	2.65	0.093	0.104
D	0.35	0.49	0.014	0.019
F	0.50	0.90	0.020	0.035
G	1.27 BSC		0.050 BSC	
J	0.25	0.32	0.010	0.012
K	0.10	0.25	0.004	0.009
M	0°	7°	0°	7°
P	10.05	10.55	0.395	0.415
R	0.25	0.75	0.010	0.029

D SUFFIX
CASE 751K-01
 Plastic Package
 (SO-16)
 ISSUE O

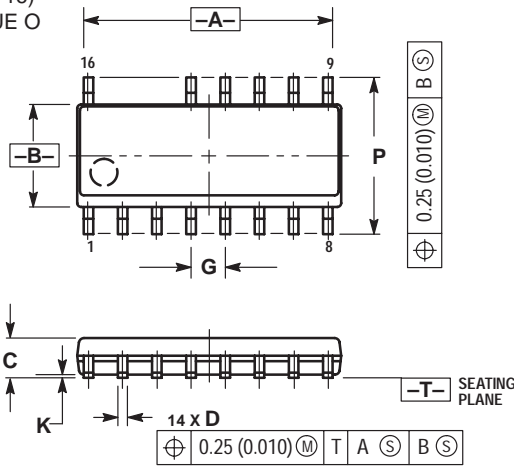
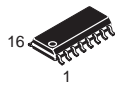

- NOTES:
1. DIMENSIONING AND TOLERANCING PER ANSI Y14.5M, 1982.
 2. CONTROLLING DIMENSION: MILLIMETER.
 3. DIMENSIONS A AND B DO NOT INCLUDE MOLD PROTRUSION.
 4. MAXIMUM MOLD PROTRUSION 0.15 (0.006) PER SIDE.
 5. DIMENSION D DOES NOT INCLUDE DAMBAR PROTRUSION. ALLOWABLE DAMBAR PROTRUSION SHALL BE 0.127 (0.005) TOTAL IN EXCESS OF THE D DIMENSION AT MAXIMUM MATERIAL CONDITION.

DIM	MILLIMETERS		INCHES	
	MIN	MAX	MIN	MAX
A	9.80	10.00	0.368	0.393
B	3.80	4.00	0.150	0.157
C	1.35	1.75	0.054	0.068
D	0.35	0.49	0.014	0.019
F	0.40	1.25	0.016	0.049
G	1.27 BSC		0.050 BSC	
J	0.19	0.25	0.008	0.009
K	0.10	0.25	0.004	0.009
M	0°	7°	0°	7°
P	5.80	6.20	0.229	0.244
R	0.25	0.50	0.010	0.019

DW SUFFIX
CASE 751N-01
 Plastic Package
 (SOP-16L)
 ISSUE O

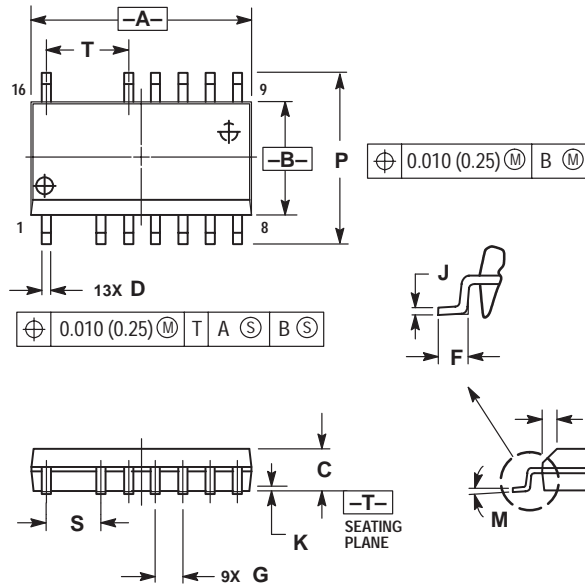
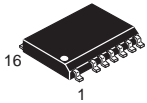

- NOTES:
1. DIMENSIONING AND TOLERANCING PER ANSI Y14.5M, 1982.
 2. CONTROLLING DIMENSION: MILLIMETER.
 3. DIMENSIONS A AND B DO NOT INCLUDE MOLD PROTRUSION.
 4. MAXIMUM MOLD PROTRUSION 0.15 (0.006) PER SIDE.
 5. DIMENSION D DOES NOT INCLUDE DAMBAR PROTRUSION. ALLOWABLE DAMBAR PROTRUSION SHALL BE 0.13 (0.005) TOTAL IN EXCESS OF D DIMENSION AT MAXIMUM MATERIAL CONDITION.

DIM	MILLIMETERS		INCHES	
	MIN	MAX	MIN	MAX
A	10.15	10.45	0.400	0.411
B	7.40	7.60	0.292	0.299
C	2.35	2.65	0.093	0.104
D	0.35	0.49	0.014	0.019
F	0.50	0.90	0.020	0.035
G	1.27 BSC		0.050 BSC	
J	0.25	0.32	0.010	0.012
K	0.10	0.25	0.004	0.009
M	0°	7°	0°	7°
P	10.05	10.55	0.395	0.415
R	0.25	0.75	0.010	0.029
S	2.54 BSC		0.100 BSC	
T	3.81 BSC		0.150 BSC	

CASE 762-01
 Plastic Medium Power Package
 (SIP-9)
 ISSUE C

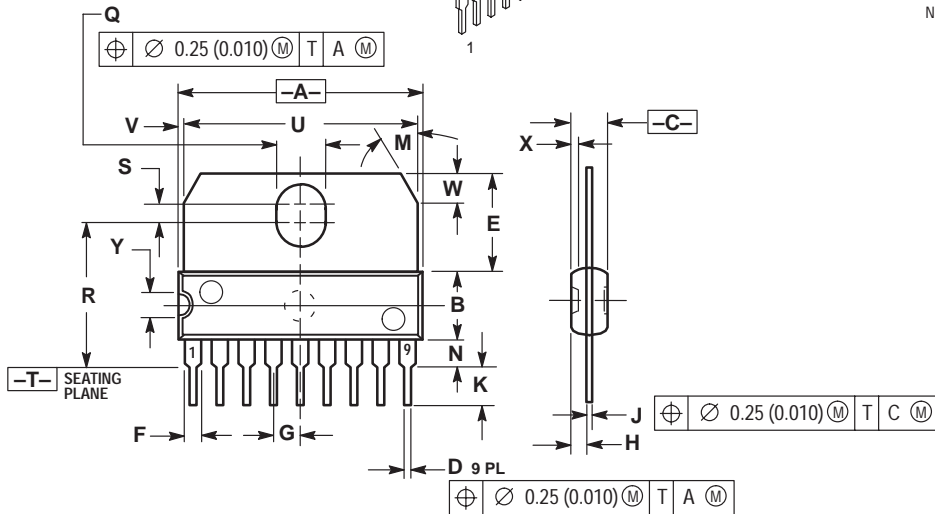
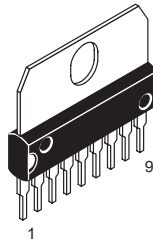

- NOTES:
 1. DIMENSIONING AND TOLERANCING PER ANSI Y14.5, 1982.
 2. CONTROLLING DIMENSION: MILLIMETER.

DIM	MILLIMETERS		INCHES	
	MIN	MAX	MIN	MAX
A	22.40	23.00	0.873	0.897
B	6.40	6.60	0.252	0.260
C	3.45	3.65	0.135	1.143
D	0.40	0.55	0.015	0.021
E	9.35	9.60	0.368	0.377
F	1.40	1.60	0.055	0.062
G	2.54 BSC		0.100 BSC	
H	1.51	1.71	0.059	0.067
J	0.360	0.400	0.014	0.015
K	3.95	4.20	0.155	0.165
M	30° BSC		30° BSC	
N	2.50	2.70	0.099	0.106
Q	3.15	3.45	0.124	0.135
R	13.60	13.90	0.535	0.547
S	1.65	1.95	0.064	0.076
U	22.00	22.20	0.866	0.874
V	0.55	0.75	0.021	0.029
W	2.89 BSC		0.113 BSC	
X	0.65	0.75	0.025	0.029
Y	2.70	2.80	0.106	0.110

FN SUFFIX
CASE 775-02
 Plastic Package
 (PLCC-20)
 ISSUE C

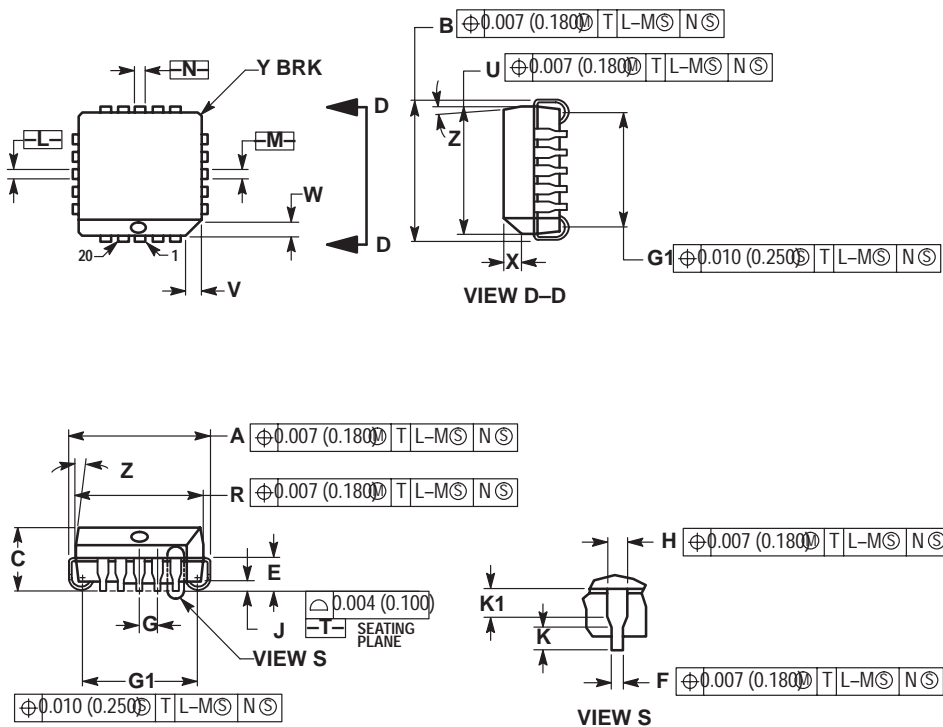
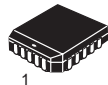

- NOTES:
 1. DATUMS -L-, -M-, AND -N- DETERMINED WHERE TOP OF LEAD SHOULDER EXITS PLASTIC BODY AT MOLD PARTING LINE.
 2. DIMENSION G1, TRUE POSITION TO BE MEASURED AT DATUM -T-, SEATING PLANE.
 3. DIMENSIONS R AND U DO NOT INCLUDE MOLD FLASH. ALLOWABLE MOLD FLASH IS 0.010 (0.250) PER SIDE.
 4. DIMENSIONING AND TOLERANCING PER ANSI Y14.5M, 1982.
 5. CONTROLLING DIMENSION: INCH.
 6. THE PACKAGE TOP MAY BE SMALLER THAN THE PACKAGE BOTTOM BY UP TO 0.012 (0.300). DIMENSIONS R AND U ARE DETERMINED AT THE OUTERMOST EXTREMES OF THE PLASTIC BODY EXCLUSIVE OF MOLD FLASH, TIE BAR BURRS, GATE BURRS AND INTERLEAD FLASH, BUT INCLUDING ANY MISMATCH BETWEEN THE TOP AND BOTTOM OF THE PLASTIC BODY.
 7. DIMENSION H DOES NOT INCLUDE DAMBAR PROTRUSION OR INTRUSION. THE DAMBAR PROTRUSION(S) SHALL NOT CAUSE THE H DIMENSION TO BE GREATER THAN 0.037 (0.940). THE DAMBAR INTRUSION(S) SHALL NOT CAUSE THE H DIMENSION TO BE SMALLER THAN 0.025 (0.635).

DIM	INCHES		MILLIMETERS	
	MIN	MAX	MIN	MAX
A	0.385	0.395	9.78	10.03
B	0.385	0.395	9.78	10.03
C	0.165	0.180	4.20	4.57
E	0.090	0.110	2.29	2.79
F	0.013	0.019	0.33	0.48
G	0.050 BSC		1.27 BSC	
H	0.026	0.032	0.66	0.81
J	0.020	---	0.51	---
K	0.025	---	0.64	---
R	0.350	0.356	8.89	9.04
U	0.350	0.356	8.89	9.04
V	0.042	0.048	1.07	1.21
W	0.042	0.048	1.07	1.21
X	0.042	0.056	1.07	1.42
Y	---	0.020	---	0.50
Z	2°	10°	---	10°
G1	0.310	0.330	7.88	8.38
K1	0.040	---	1.02	---

FN SUFFIX
CASE 776-02
 Plastic Package
 (PLCC-28)
 ISSUE D

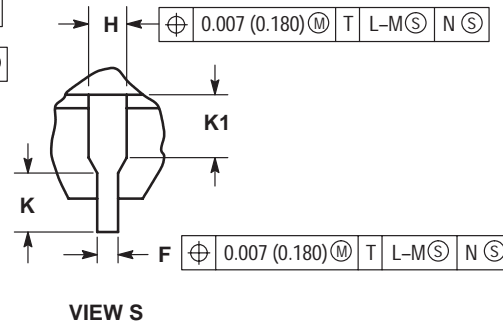
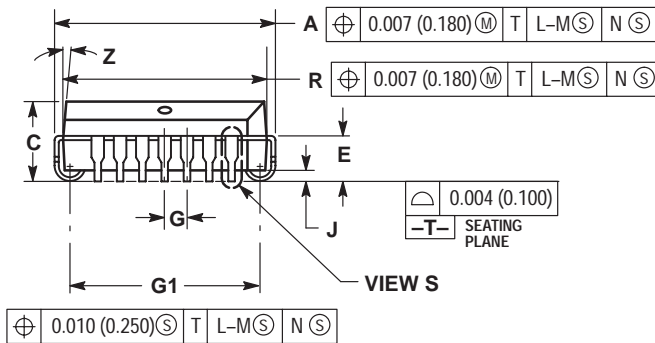
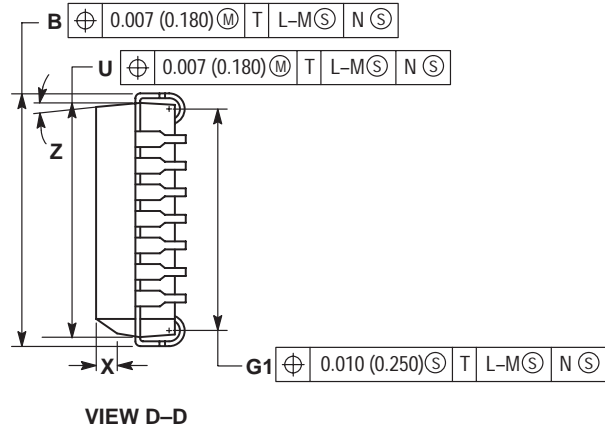
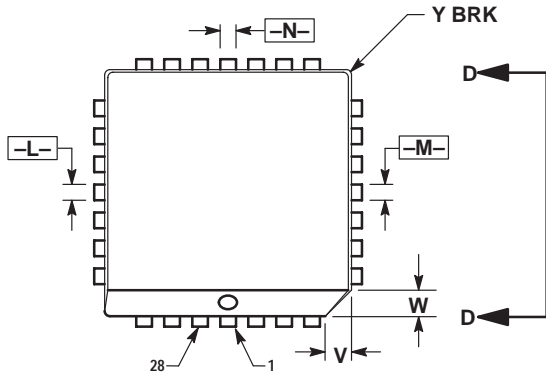
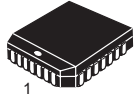

NOTES:

- DATUMS -L-, -M-, AND -N- DETERMINED WHERE TOP OF LEAD SHOULDER EXITS PLASTIC BODY AT MOLD PARTING LINE.
- DIMENSION G1, TRUE POSITION TO BE MEASURED AT DATUM -T-, SEATING PLANE.
- DIMENSIONS R AND U DO NOT INCLUDE MOLD FLASH. ALLOWABLE MOLD FLASH IS 0.010 (0.250) PER SIDE.
- DIMENSIONING AND TOLERANCING PER ANSI Y14.5M, 1982.
- CONTROLLING DIMENSION: INCH.
- THE PACKAGE TOP MAY BE SMALLER THAN THE PACKAGE BOTTOM BY UP TO 0.012 (0.300). DIMENSIONS R AND U ARE DETERMINED AT THE OUTERMOST EXTREMES OF THE PLASTIC BODY EXCLUSIVE OF MOLD FLASH, TIE BAR BURRS, GATE BURRS AND INTERLEAD FLASH, BUT INCLUDING ANY MISMATCH BETWEEN THE TOP AND BOTTOM OF THE PLASTIC BODY.
- DIMENSION H DOES NOT INCLUDE DAMBAR PROTRUSION OR INTRUSION. THE DAMBAR PROTRUSION(S) SHALL NOT CAUSE THE H DIMENSION TO BE GREATER THAN 0.037 (0.940). THE DAMBAR INTRUSION(S) SHALL NOT CAUSE THE H DIMENSION TO BE SMALLER THAN 0.025 (0.635).

DIM	INCHES		MILLIMETERS	
	MIN	MAX	MIN	MAX
A	0.485	0.495	12.32	12.57
B	0.485	0.495	12.32	12.57
C	0.165	0.180	4.20	4.57
E	0.090	0.110	2.29	2.79
F	0.013	0.019	0.33	0.48
G	0.050 BSC		1.27 BSC	
H	0.026	0.032	0.66	0.81
J	0.020	---	0.51	---
K	0.025	---	0.64	---
R	0.450	0.456	11.43	11.58
U	0.450	0.456	11.43	11.58
V	0.042	0.048	1.07	1.21
W	0.042	0.048	1.07	1.21
X	0.042	0.056	1.07	1.42
Y	---	0.020	---	0.50
Z	2°	10°	2°	10°
G1	0.410	0.430	10.42	10.92
K1	0.040	---	1.02	---

FN SUFFIX
CASE 777-02
 Plastic Package
 (PLCC)
 ISSUE C

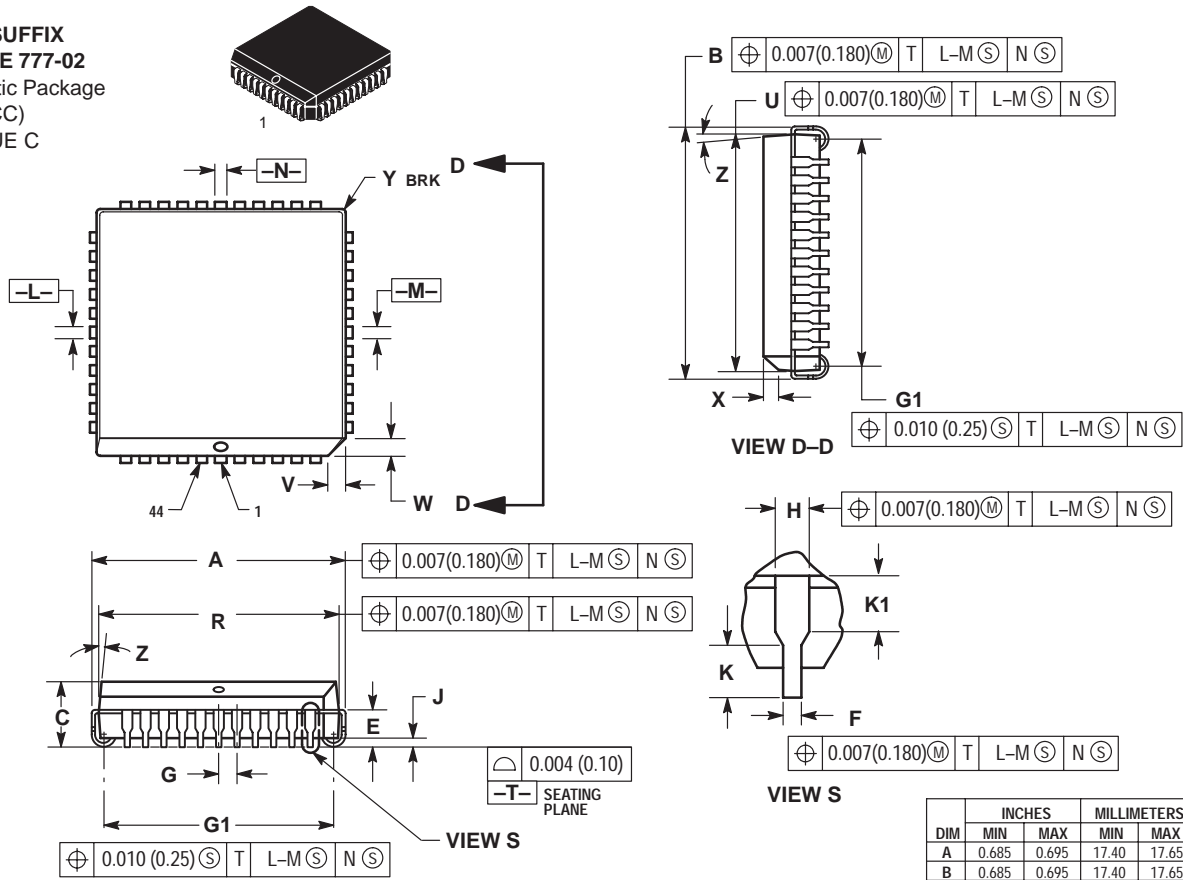

- NOTES:
- DATUMS -L-, -M-, AND -N- ARE DETERMINED WHERE TOP OF LEAD SHOULDER EXITS PLASTIC BODY AT MOLD PARTING LINE.
 - DIMENSION G1, TRUE POSITION TO BE MEASURED AT DATUM -T-, SEATING PLANE.
 - DIMENSIONS R AND U DO NOT INCLUDE MOLD FLASH. ALLOWABLE MOLD FLASH IS 0.010 (0.25) PER SIDE.
 - DIMENSIONING AND TOLERANCING PER ANSI Y14.5M, 1982.
 - CONTROLLING DIMENSION: INCH.

- THE PACKAGE TOP MAY BE SMALLER THAN THE PACKAGE BOTTOM BY UP TO 0.012 (0.300). DIMENSIONS R AND U ARE DETERMINED AT THE OUTERMOST EXTREMES OF THE PLASTIC BODY EXCLUSIVE OF MOLD FLASH, TIE BAR BURRS, GATE BURRS AND INTERLEAD FLASH, BUT INCLUDING ANY MISMATCH BETWEEN THE TOP AND BOTTOM OF THE PLASTIC BODY.
- DIMENSION H DOES NOT INCLUDE DAMBAR PROTRUSION OR INTRUSION. THE DAMBAR PROTRUSION(S) SHALL NOT CAUSE THE H DIMENSION TO BE GREATER THAN 0.037 (0.940). THE DAMBAR INTRUSION(S) SHALL NOT CAUSE THE H DIMENSION TO BE SMALLER THAN 0.025 (0.635).

DIM	INCHES		MILLIMETERS	
	MIN	MAX	MIN	MAX
A	0.685	0.695	17.40	17.65
B	0.685	0.695	17.40	17.65
C	0.165	0.180	4.20	4.57
E	0.090	0.110	2.29	2.79
F	0.013	0.019	0.33	0.48
G	0.050 BSC		1.27 BSC	
H	0.026	0.032	0.66	0.81
J	0.020	---	0.51	---
K	0.025	---	0.64	---
R	0.650	0.656	16.51	16.66
U	0.650	0.656	16.51	16.66
V	0.042	0.048	1.07	1.21
W	0.042	0.048	1.07	1.21
X	0.042	0.056	1.07	1.42
Y	---	0.020	---	0.50
Z	2°	10°	2°	10°
G1	0.610	0.630	15.50	16.00
K1	0.040	---	1.02	---

M SUFFIX
CASE 803C
PRELIMINARY
 Plastic Package

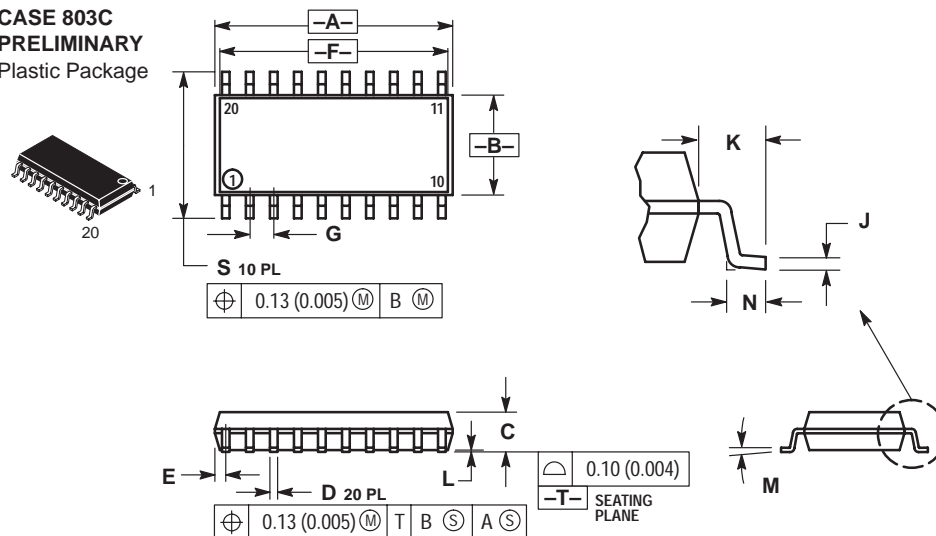

- NOTES:
- DIMENSIONING AND TOLERANCING PER ANSI Y14.5M, 1982.
 - CONTROLLING DIMENSION: MILLIMETER.
 - DIMENSIONS A AND B DO NOT INCLUDE MOLD PROTRUSION.
 - MAXIMUM MOLD PROTRUSION 0.15 (0.008) PER SIDE.
 - DIMENSION D DOES NOT INCLUDE DAMBAR PROTRUSION. ALLOWABLE DAMBAR PROTRUSION SHALL BE 0.13 (0.006) TOTAL IN EXCESS OF THE D DIMENSION AT MAXIMUM MATERIAL CONDITION.

DIM	MILLIMETERS		INCHES	
	MIN	MAX	MIN	MAX
A	12.35	12.80	0.486	0.504
B	5.10	5.45	0.201	0.215
C	1.95	2.05	0.077	0.081
D	0.35	0.50	0.014	0.020
E	---	0.81	---	0.032
F	12.40*		0.488*	
G	1.15	1.39	0.045	0.055
H	0.59	0.81	0.023	0.032
J	0.18	0.27	0.007	0.011
K	1.10	1.50	0.043	0.059
L	0.05	0.20	0.001	0.008
M	0°	10°	0°	10°
N	0.50	0.85	0.020	0.033
S	7.40	8.20	0.291	0.323

*APPROXIMATE

TV SUFFIX
CASE 821C-04
 Plastic Package
 (15-Pin ZIP)
 ISSUE D

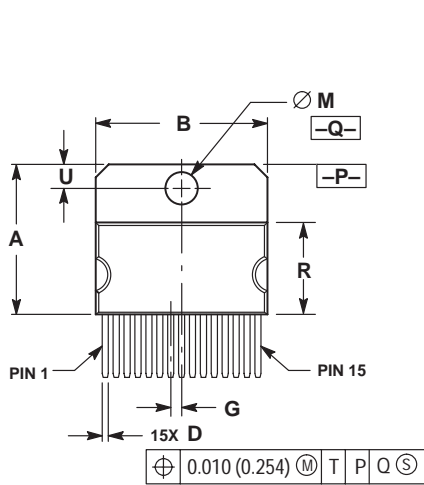
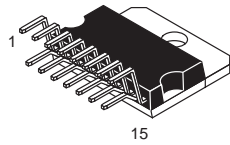

\oplus	0.010 (0.254)	\textcircled{M}	T	P	Q	\textcircled{S}
----------	---------------	-------------------	---	---	---	-------------------

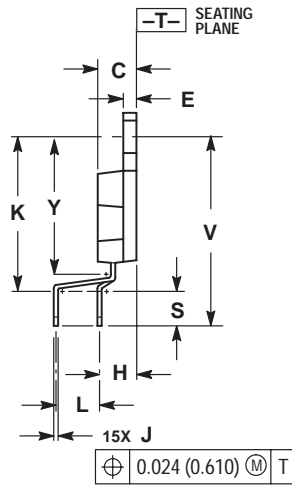

\oplus	0.024 (0.610)	\textcircled{M}	T
----------	---------------	-------------------	---

NOTES:

1. DIMENSIONING AND TOLERANCING PER ANSI Y14.5M, 1982.
2. CONTROLLING DIMENSION: INCH.
3. DIMENSION R DOES NOT INCLUDE MOLD FLASH OR PROTRUSIONS.
4. DIMENSION B DOES NOT INCLUDE MOLD FLASH OR PROTRUSIONS.
5. MOLD FLASH OR PROTRUSIONS SHALL NOT EXCEED 0.010 (0.250).
6. DIMENSION D DOES NOT INCLUDE DAMBAR PROTRUSION. ALLOWABLE PROTRUSION SHALL BE 0.003 (0.076) TOTAL IN EXCESS OF THE D DIMENSION, AT MAXIMUM MATERIAL CONDITION.

DIM	INCHES		MILLIMETERS	
	MIN	MAX	MIN	MAX
A	0.684	0.694	17.374	17.627
B	0.784	0.792	19.914	20.116
C	0.173	0.181	4.395	4.597
D	0.024	0.031	0.610	0.787
E	0.058	0.062	1.473	1.574
G	0.050 BSC		1.270 BSC	
H	0.169 BSC		4.293 BSC	
J	0.018	0.024	0.458	0.609
K	0.700	0.710	17.780	18.034
L	0.200 BSC		5.080 BSC	
M	0.148	0.151	3.760	3.835
R	0.416	0.426	10.567	10.820
S	0.157	0.167	3.988	4.242
U	0.105	0.115	2.667	2.921
V	0.868 REF		22.047 REF	
Y	0.625	0.639	15.875	16.231

T SUFFIX
CASE 821D-03
 Plastic Package
 ISSUE C

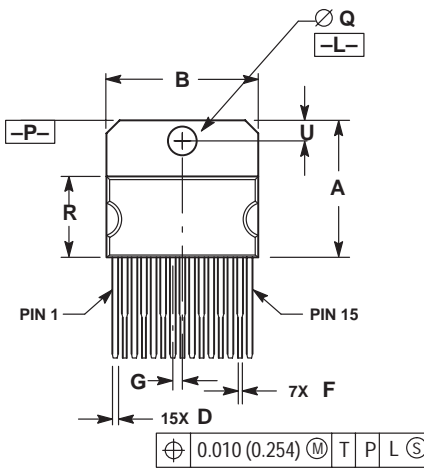
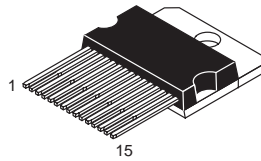

\oplus	0.010 (0.254)	\textcircled{M}	T	P	L	\textcircled{S}
----------	---------------	-------------------	---	---	---	-------------------

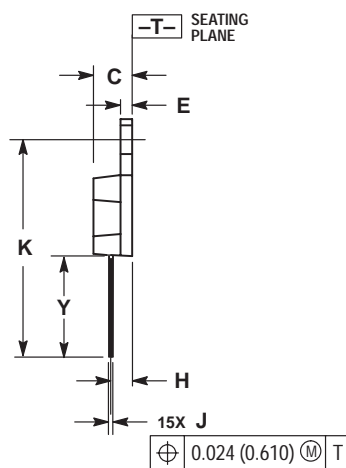

\oplus	0.024 (0.610)	\textcircled{M}	T
----------	---------------	-------------------	---

NOTES:

1. DIMENSIONING AND TOLERANCING PER ANSI Y14.5M, 1982.
2. CONTROLLING DIMENSION: INCH.
3. DIMENSION R DOES NOT INCLUDE MOLD FLASH OR PROTRUSIONS.
4. DIMENSION B DOES NOT INCLUDE MOLD FLASH OR PROTRUSIONS.
5. MOLD FLASH OR PROTRUSIONS SHALL NOT EXCEED 0.010 (0.250).
6. DELETED
7. DIMENSION D DOES NOT INCLUDE DAMBAR PROTRUSION. ALLOWABLE PROTRUSION SHALL BE 0.003 (0.076) TOTAL IN EXCESS OF THE D DIMENSION, AT MAXIMUM MATERIAL CONDITION.

DIM	INCHES		MILLIMETERS	
	MIN	MAX	MIN	MAX
A	0.681	0.694	17.298	17.627
B	0.784	0.792	19.914	20.116
C	0.173	0.181	4.395	4.597
D	0.024	0.031	0.610	0.787
E	0.058	0.062	1.473	1.574
F	0.016	0.023	0.407	0.584
G	0.050 BSC		1.270 BSC	
H	0.110 BSC		2.794 BSC	
J	0.018	0.024	0.458	0.609
K	1.078	1.086	27.382	27.584
Q	0.148	0.151	3.760	3.835
R	0.416	0.426	10.567	10.820
U	0.110 BSC		2.794 BSC	
Y	0.503 REF		12.776 REF	

FTB SUFFIX
CASE 824D-01
 Plastic Package
 (TQFP-44)
 ISSUE O

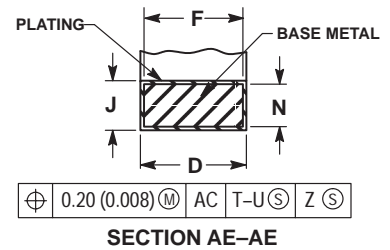
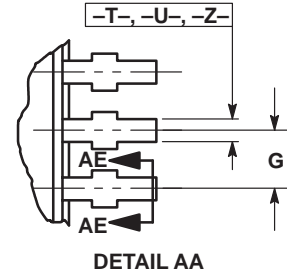
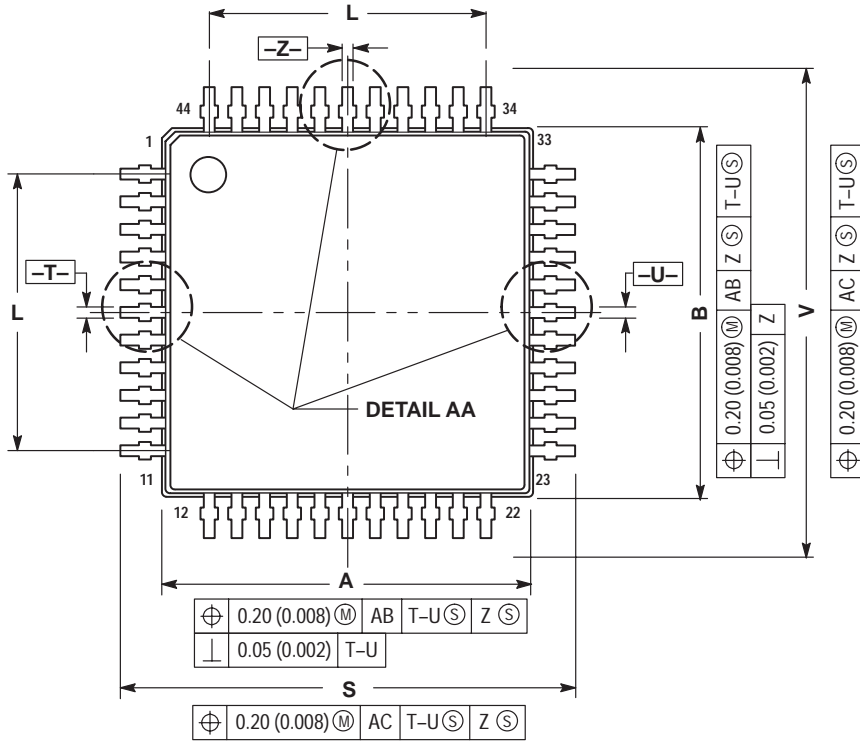
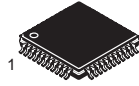

- NOTES:
- DIMENSIONING AND TOLERANCING PER ANSI Y14.5M, 1982.
 - CONTROLLING DIMENSION: MILLIMETER.
 - DATUM PLANE -AB- IS LOCATED AT BOTTOM OF LEAD AND IS COINCIDENT WITH THE LEAD WHERE THE LEAD EXITS THE PLASTIC BODY AT THE BOTTOM OF THE PARTING LINE.
 - DATUMS -T-, -U- AND -Z- TO BE DETERMINED AT DATUM PLANE -AB-.
 - DIMENSIONS S AND V TO BE DETERMINED AT SEATING PLANE -AC-.
 - DIMENSIONS A AND B DO NOT INCLUDE MOLD PROTRUSION. ALLOWABLE PROTRUSION IS 0.25 (0.010) PER SIDE. DIMENSIONS A AND B DO INCLUDE MOLD MISMATCH AND ARE DETERMINED AT DATUM PLANE -AB-.
 - DIMENSION D DOES NOT INCLUDE DAMBAR PROTRUSION. DAMBAR PROTRUSION SHALL NOT CAUSE THE D DIMENSION TO EXCEED 0.530 (0.021).

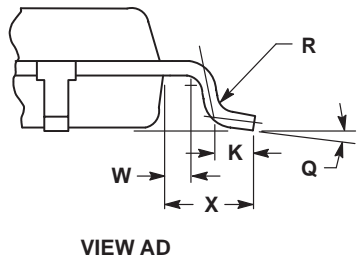
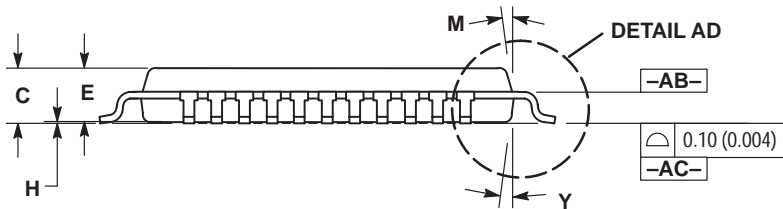

DIM	MILLIMETERS		INCHES	
	MIN	MAX	MIN	MAX
A	9.950	10.050	0.392	0.396
B	9.950	10.050	0.392	0.396
C	1.400	1.600	0.055	0.063
D	0.300	0.450	0.012	0.018
E	1.350	1.450	0.053	0.057
F	0.300	0.400	0.012	0.016
G	0.800 BSC		0.031 BSC	
H	0.050	0.150	0.002	0.006
J	0.090	0.200	0.004	0.008
K	0.450	0.550	0.018	0.022
L	8.000 BSC		0.315 BSC	
M	12° REF		12° REF	
N	0.090	0.160	0.004	0.006
Q	1°	5°	1°	5°
R	0.100	0.200	0.004	0.008
S	11.900	12.100	0.469	0.476
V	11.900	12.100	0.469	0.476
W	0.200 REF		0.008 REF	
X	1.000 REF		0.039 REF	
Y	12° REF		12° REF	

FB SUFFIX
CASE 824E-02
 Plastic Package
 (QFP)
 ISSUE A

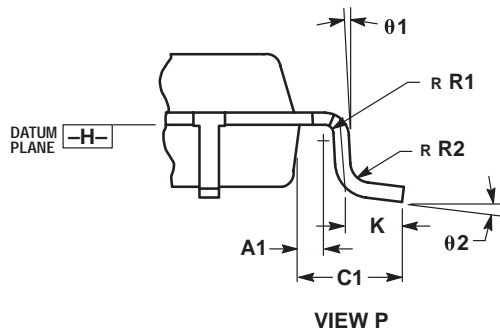
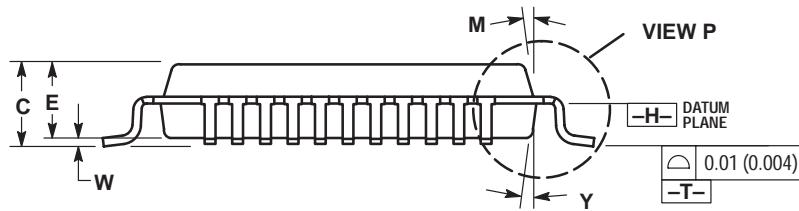
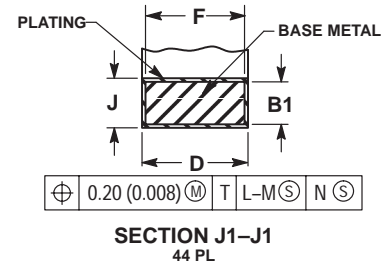
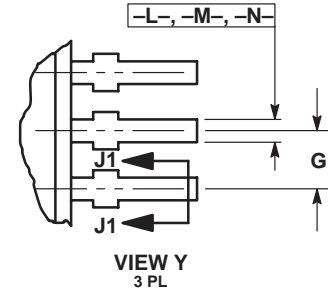
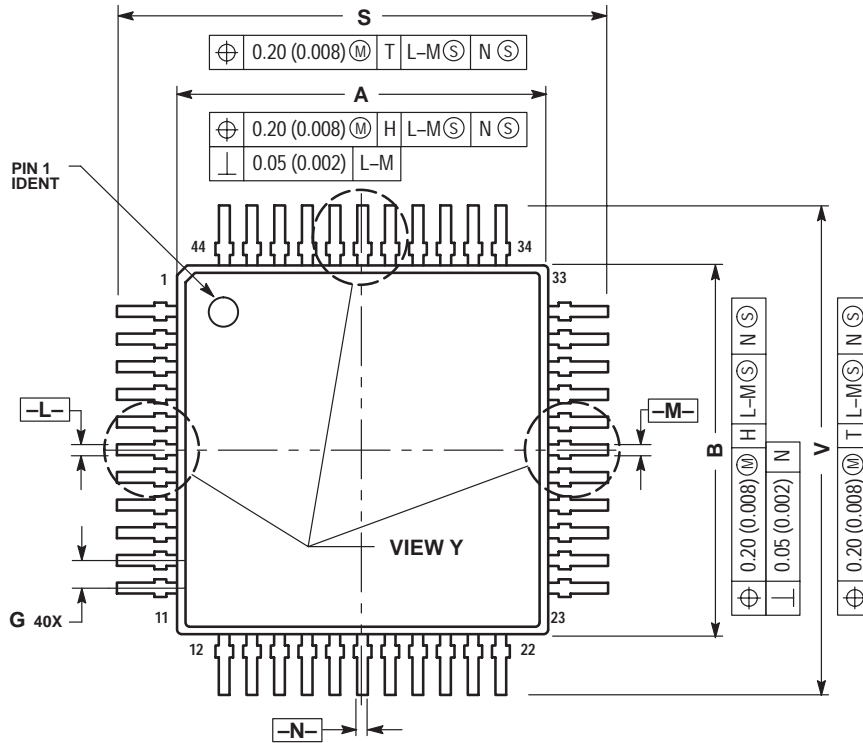
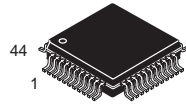

- NOTES:
1. DIMENSIONING AND TOLERANCING PER ANSI Y14.5M, 1982.
 2. CONTROLLING DIMENSION: MILLIMETER.
 3. DATUM PLANE -H- IS LOCATED AT BOTTOM OF LEAD AND IS COINCIDENT WITH THE LEAD WHERE THE LEAD EXITS THE PLASTIC BODY AT THE BOTTOM OF THE PARTING LINE.
 4. DATUMS -L-, -M- AND -N- TO BE DETERMINED AT DATUM PLANE -H-.
 5. DIMENSIONS S AND V TO BE DETERMINED AT SEATING PLANE -T-.
 6. DIMENSIONS A AND B DO NOT INCLUDE MOLD PROTRUSION. ALLOWABLE PROTRUSION IS 0.25 (0.010) PER SIDE. DIMENSIONS A AND B DO INCLUDE MOLD MISMATCH AND ARE DETERMINED AT DATUM PLANE -H-.
 7. DIMENSION D DOES NOT INCLUDE DAMBAR PROTRUSION. DAMBAR PROTRUSION SHALL NOT CAUSE THE D DIMENSION TO EXCEED 0.530 (0.021).

DIM	MILLIMETERS		INCHES	
	MIN	MAX	MIN	MAX
A	9.90	10.10	0.390	0.398
B	9.90	10.10	0.390	0.398
C	2.00	2.21	0.079	0.087
D	0.30	0.45	0.0118	0.0177
E	2.00	2.10	0.079	0.083
F	0.30	0.40	0.012	0.016
G	0.80 BSC		0.031 BSC	
J	0.13	0.23	0.005	0.009
K	0.65	0.95	0.026	0.037
M	5° 10°		5° 10°	
S	12.95	13.45	0.510	0.530
V	12.95	13.45	0.510	0.530
W	0.000	0.210	0.000	0.008
Y	5° 10°		5° 10°	
A1	0.450 REF		0.018 REF	
B1	0.130	0.170	0.005	0.007
C1	1.600 REF		0.063 REF	
R1	0.130	0.300	0.005	0.012
R2	0.130	0.300	0.005	0.012
theta1	5° 10°		5° 10°	
theta2	0° 7°		0° 7°	

FB SUFFIX
CASE 840F-01
 Plastic Package
 ISSUE O

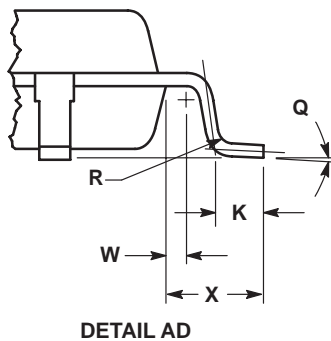
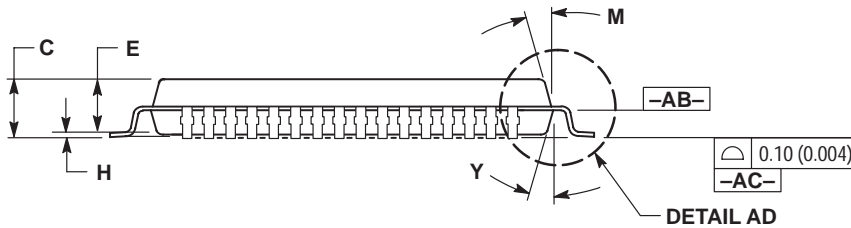
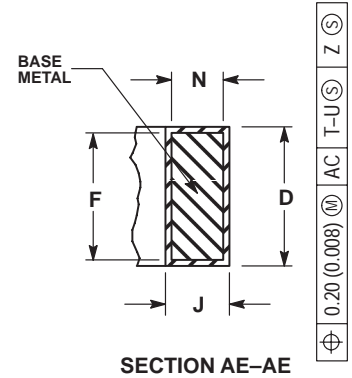
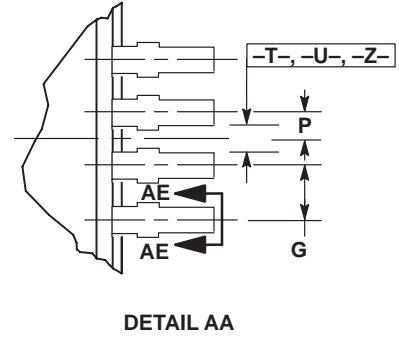
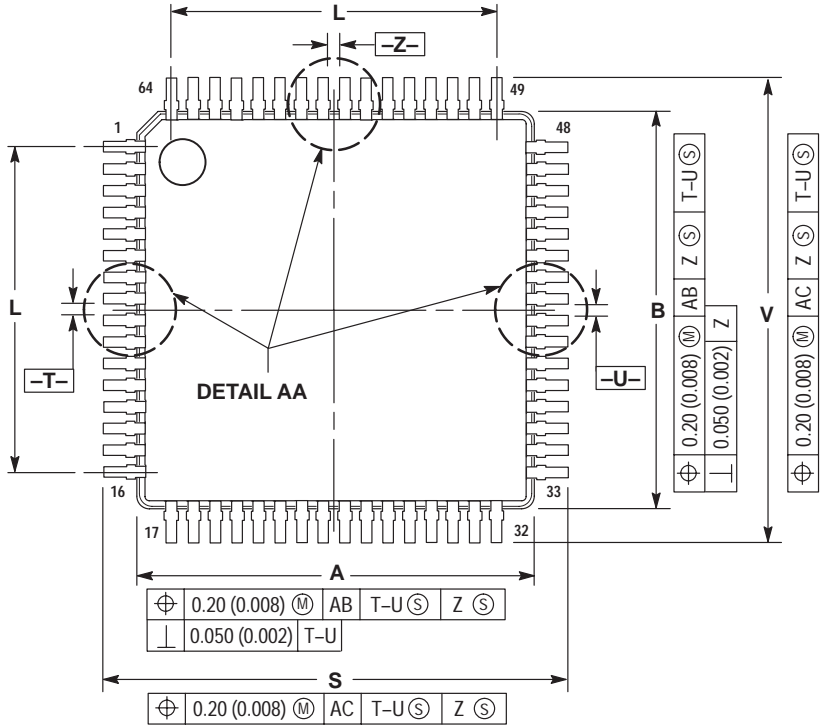
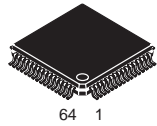

- NOTES:
1. DIMENSIONING AND TOLERANCING PER ANSI Y14.5M, 1982.
 2. CONTROLLING DIMENSION: MILLIMETER.
 3. DATUM PLANE -AB- IS LOCATED AT BOTTOM OF LEAD AND IS COINCIDENT WITH THE LEAD WHERE THE LEAD EXITS THE PLASTIC BODY AT THE BOTTOM OF THE PARTING LINE.
 4. DATUMS -T-, -U- AND -Z- TO BE DETERMINED AT DATUM PLANE -AC-.
 5. DIMENSIONS S AND V TO BE DETERMINED AT SEATING PLANE -AC-.
 6. DIMENSIONS A AND B DO NOT INCLUDE MOLD PROTRUSION. ALLOWABLE PROTRUSION IS 0.25 (0.010) PER SIDE. DIMENSIONS A AND B DO INCLUDE MOLD MISMATCH AND ARE DETERMINED AT DATUM PLANE -AB-.
 7. DIMENSION D DOES NOT INCLUDE DAMBAR PROTRUSION. DAMBAR PROTRUSION SHALL NOT CAUSE THE D DIMENSION TO EXCEED 0.350 (0.014).

DIM	MILLIMETERS		INCHES	
	MIN	MAX	MIN	MAX
A	9.950	10.050	0.392	0.396
B	9.950	10.050	0.392	0.396
C	1.400	1.600	0.055	0.063
D	0.170	0.270	0.007	0.011
E	1.350	1.450	0.053	0.057
F	0.170	0.230	0.007	0.009
G	0.500 BSC		0.020 BSC	
H	0.050	0.150	0.002	0.006
J	0.090	0.200	0.004	0.008
K	0.450	0.550	0.018	0.022
L	7.500 BSC		0.295 BSC	
M	12° REF		12° REF	
N	0.090	0.160	0.004	0.006
P	0.250 BSC		0.010 BSC	
Q	1°	5°	1°	5°
R	0.100	0.200	0.004	0.008
S	11.900	12.100	0.469	0.476
V	11.900	12.100	0.469	0.476
W	0.200 REF		0.008 REF	
X	1.000 REF		0.039 REF	
Y	12° REF		12° REF	

DM SUFFIX
CASE 846A-02
 Plastic Package
 (Micro-8)
 ISSUE C

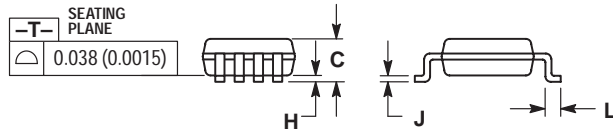
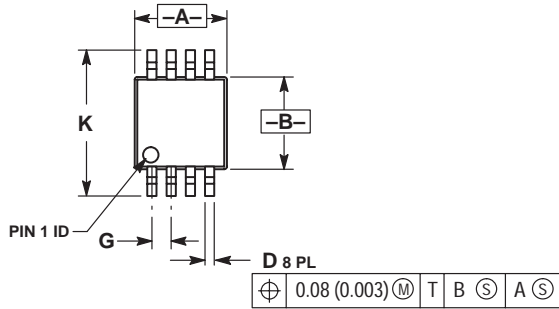

NOTES:

1. DIMENSIONING AND TOLERANCING PER ANSI Y14.5M, 1982.
2. CONTROLLING DIMENSION: MILLIMETER.
3. DIMENSION A DOES NOT INCLUDE MOLD FLASH, PROTRUSIONS OR GATE BURRS. MOLD FLASH, PROTRUSIONS OR GATE BURRS SHALL NOT EXCEED 0.15 (0.006) PER SIDE.
4. DIMENSION B DOES NOT INCLUDE INTERLEAD FLASH OR PROTRUSION. INTERLEAD FLASH OR PROTRUSION SHALL NOT EXCEED 0.25 (0.010) PER SIDE.

DIM	MILLIMETERS		INCHES	
	MIN	MAX	MIN	MAX
A	2.90	3.10	0.114	0.122
B	2.90	3.10	0.114	0.122
C	---	1.10	---	0.043
D	0.25	0.40	0.010	0.016
G	0.65 BSC		0.026 BSC	
H	0.05	0.15	0.002	0.006
J	0.13	0.23	0.005	0.009
K	4.75	5.05	0.187	0.199
L	0.40	0.70	0.016	0.028

FB SUFFIX
CASE 848B-04
 Plastic Package
 (TQFP-52)
 ISSUE C

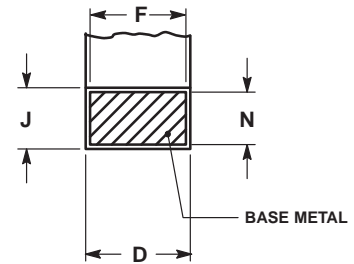
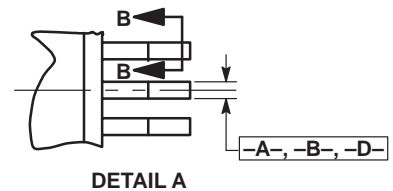
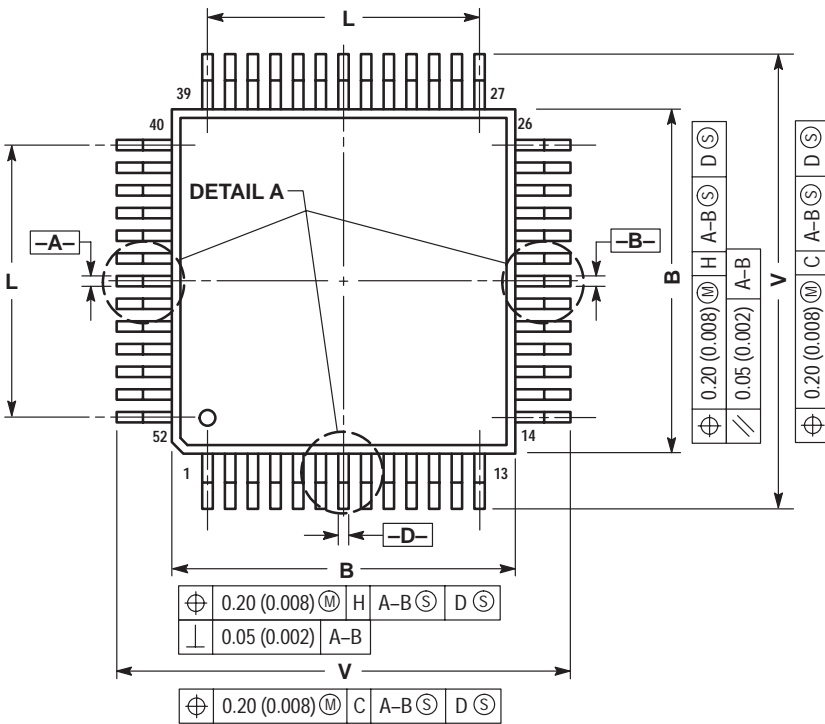
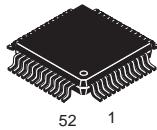

⊕	0.02 (0.008) (M)	C	A-B (S)	D (S)
---	------------------	---	---------	-------

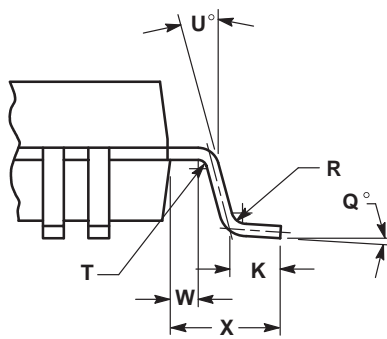
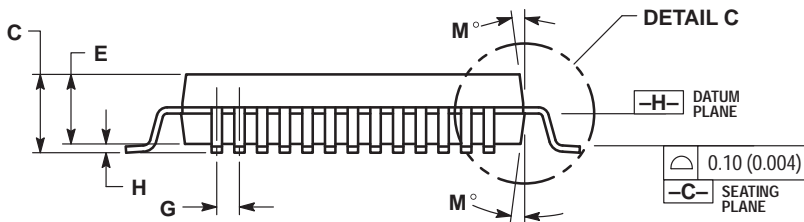

NOTES:

- DIMENSIONING AND TOLERANCING PER ANSI Y14.5M, 1982.
- CONTROLLING DIMENSION: MILLIMETER.
- DATUM PLANE -H- IS LOCATED AT BOTTOM OF LEAD AND IS COINCIDENT WITH THE LEAD WHERE THE LEAD EXITS THE PLASTIC BODY AT THE BOTTOM OF THE PARTING LINE.
- DATUMS -A-, -B- AND -D- TO BE DETERMINED AT DATUM PLANE -H-.
- DIMENSIONS S AND V TO BE DETERMINED AT SEATING PLANE -C-.
- DIMENSIONS A AND B DO NOT INCLUDE MOLD PROTRUSION. ALLOWABLE PROTRUSION IS 0.25 (0.010) PER SIDE. DIMENSIONS A AND B DO INCLUDE MOLD MISMATCH AND ARE DETERMINED AT DATUM PLANE -H-.
- DIMENSION D DOES NOT INCLUDE DAMBAR PROTRUSION. ALLOWABLE DAMBAR PROTRUSION SHALL BE 0.08 (0.003) TOTAL IN EXCESS OF THE D DIMENSION AT MAXIMUM MATERIAL CONDITION. DAMBAR CANNOT BE LOCATED ON THE LOWER RADIUS OR THE FOOT.

DIM	MILLIMETERS		INCHES	
	MIN	MAX	MIN	MAX
A	9.90	10.10	0.390	0.398
B	9.90	10.10	0.390	0.398
C	2.10	2.45	0.083	0.096
D	0.22	0.38	0.009	0.015
E	2.00	2.10	0.079	0.083
F	0.22	0.33	0.009	0.013
G	0.65 BSC		0.026 BSC	
H	---	0.25	---	0.010
J	0.13	0.23	0.005	0.009
K	0.65	0.95	0.026	0.037
L	7.80 REF		0.307 REF	
M	5°	10°	5°	10°
N	0.13	0.17	0.005	0.007
Q	0°	7°	0°	7°
R	0.13	0.30	0.005	0.012
S	12.95	13.45	0.510	0.530
T	0.13	---	0.005	---
U	0°	---	0°	---
V	12.95	13.45	0.510	0.530
W	0.35	0.45	0.014	0.018
X	1.6 REF		0.063 REF	

FB SUFFIX
CASE 848D-03
 Plastic Package
 ISSUE C

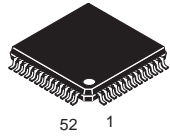

52 1

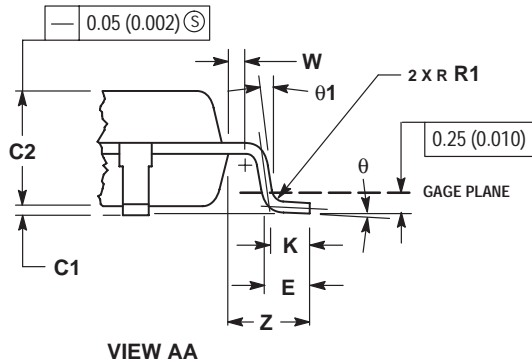
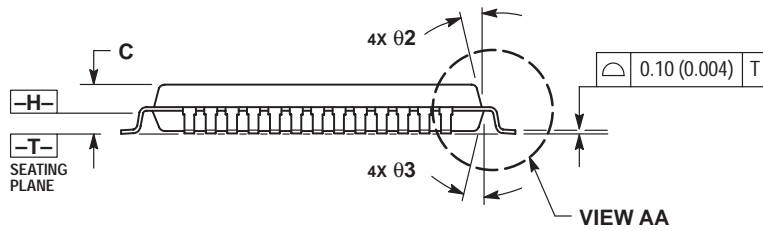
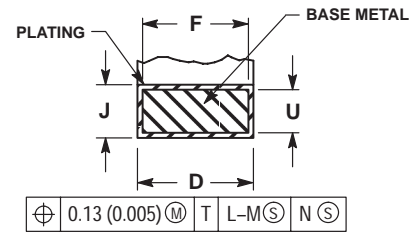
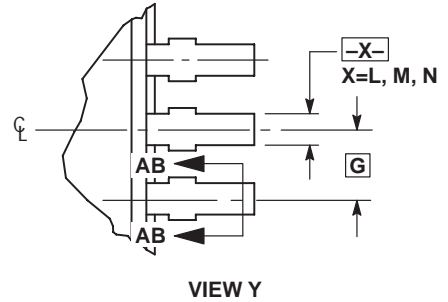
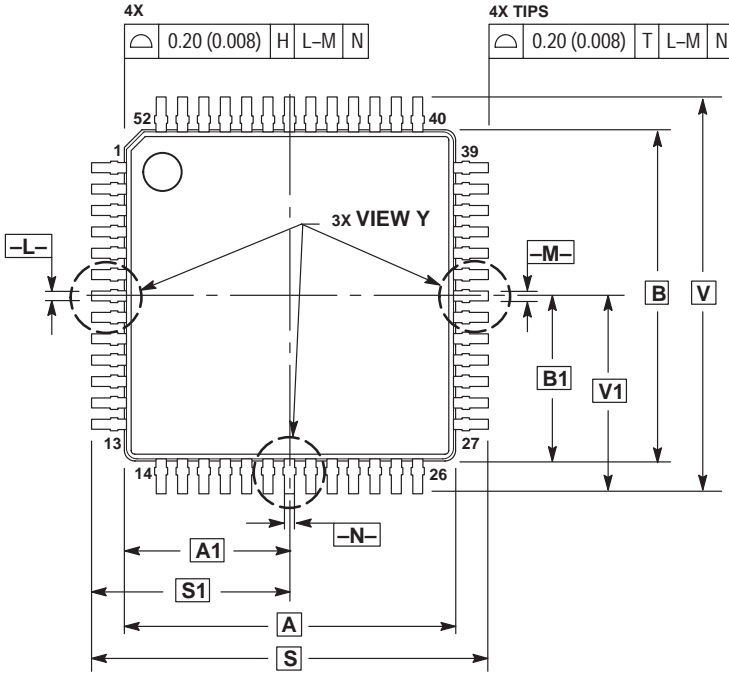

- NOTES:
1. DIMENSIONING AND TOLERANCING PER ANSI Y14.5M, 1982.
 2. CONTROLLING DIMENSION: MILLIMETER.
 3. DATUM PLANE -H- IS LOCATED AT BOTTOM OF LEAD AND IS COINCIDENT WITH THE LEAD WHERE THE LEAD EXITS THE PLASTIC BODY AT THE BOTTOM OF THE PARTING LINE.
 4. DATUMS -L-, -M- AND -N- TO BE DETERMINED AT DATUM PLANE -H-.
 5. DIMENSIONS S AND V TO BE DETERMINED AT SEATING PLANE -T-.
 6. DIMENSIONS A AND B DO NOT INCLUDE MOLD PROTRUSION. ALLOWABLE PROTRUSION IS 0.25 (0.010) PER SIDE. DIMENSIONS A AND B DO NOT INCLUDE MOLD MISMATCH AND ARE DETERMINED AT DATUM PLANE -H-.
 7. DIMENSION D DOES NOT INCLUDE DAMBAR PROTRUSION. DAMBAR PROTRUSION SHALL NOT CAUSE THE LEAD WIDTH TO EXCEED 0.46 (0.018). MINIMUM SPACE BETWEEN PROTRUSION AND ADJACENT LEAD OR PROTRUSION 0.07 (0.003).

DIM	MILLIMETERS		INCHES	
	MIN	MAX	MIN	MAX
A	10.00 BSC	0.394 BSC		
A1	5.00 BSC	0.197 BSC		
B	10.00 BSC	0.394 BSC		
B1	5.00 BSC	0.197 BSC		
C	---	1.70	---	0.067
C1	0.05	0.20	0.002	0.008
C2	1.30	1.50	0.051	0.059
D	0.20	0.40	0.008	0.016
E	0.45	0.75	0.018	0.030
F	0.22	0.35	0.009	0.014
G	0.65 BSC	0.026 BSC		
J	0.07	0.20	0.003	0.008
K	0.50 REF	0.020 REF		
R1	0.08	0.20	0.003	0.008
S	12.00 BSC	0.472 BSC		
S1	6.00 BSC	0.236 BSC		
U	0.09	0.16	0.004	0.006
V	12.00 BSC	0.472 BSC		
V1	6.00 BSC	0.236 BSC		
W	0.20 REF	0.008 REF		
Z	1.00 REF	0.039 REF		
theta	0°	7°	0°	7°
theta 1	0°	---	0°	---
theta 2	12° REF	12° REF		
theta 3	5°	13°	5°	13°

B SUFFIX
CASE 858-01
 Plastic Package
 ISSUE O

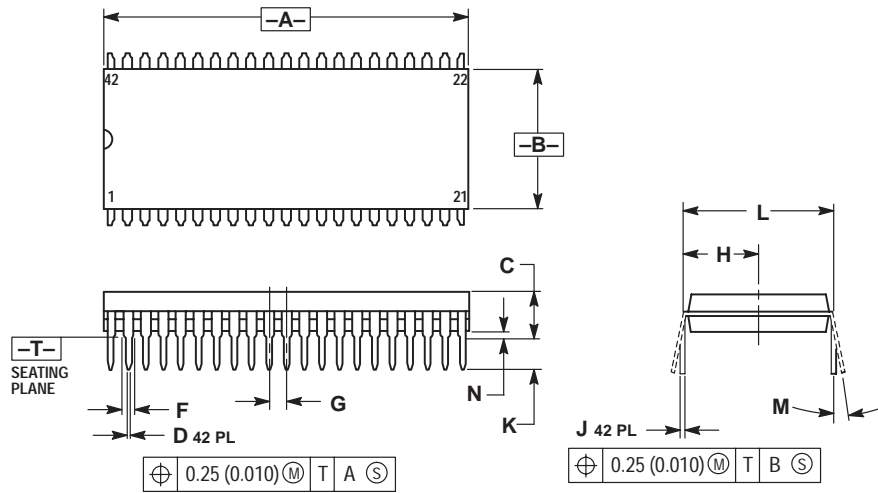
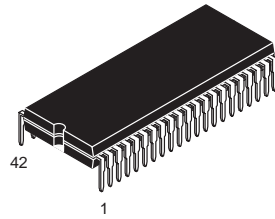

- NOTES:
1. DIMENSIONING AND TOLERANCING PER ANSI Y14.5M, 1982.
 2. CONTROLLING DIMENSION: INCH.
 3. DIMENSION L TO CENTER OF LEAD WHEN FORMED PARALLEL.
 4. DIMENSIONS A AND B DO NOT INCLUDE MOLD FLASH. MAXIMUM MOLD FLASH 0.25 (0.010).

DIM	INCHES		MILLIMETERS	
	MIN	MAX	MIN	MAX
A	1.435	1.465	36.45	37.21
B	0.540	0.560	13.72	14.22
C	0.155	0.200	3.94	5.08
D	0.014	0.022	0.36	0.56
F	0.032	0.046	0.81	1.17
G	0.070 BSC		1.778 BSC	
H	0.300 BSC		7.62 BSC	
J	0.008	0.015	0.20	0.38
K	0.115	0.135	2.92	3.43
L	0.600 BSC		15.24 BSC	
M	0°	15°	0°	15°
N	0.020	0.040	0.51	1.02

B SUFFIX
CASE 859-01
 Plastic Package
 (SDIP)
 ISSUE O

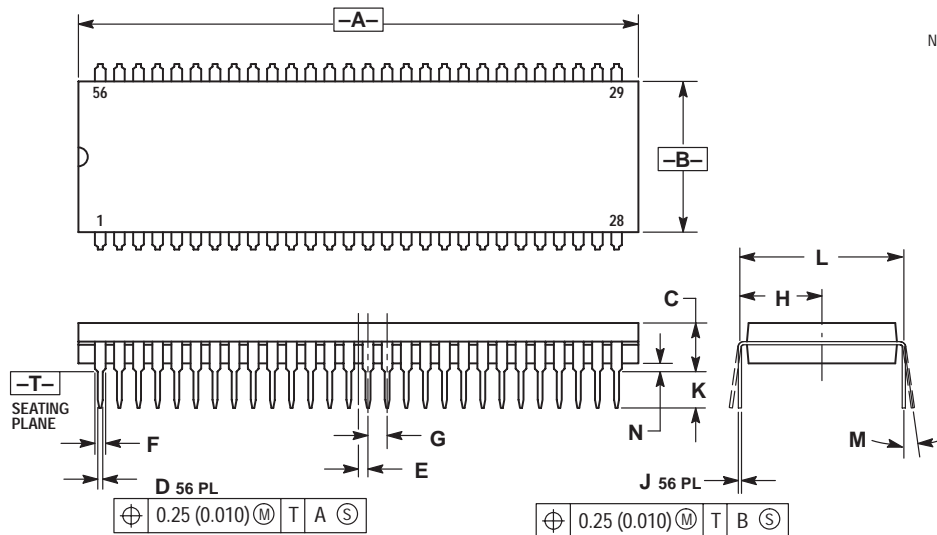
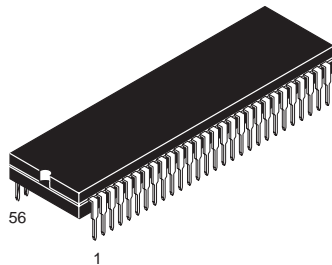

- NOTES:
1. DIMENSIONING AND TOLERANCING PER ANSI Y14.5M, 1982.
 2. CONTROLLING DIMENSION: INCH.
 3. DIMENSION L TO CENTER OF LEAD WHEN FORMED PARALLEL.
 4. DIMENSIONS A AND B DO NOT INCLUDE MOLD FLASH. MAXIMUM MOLD FLASH 0.25 (0.010)

DIM	INCHES		MILLIMETERS	
	MIN	MAX	MIN	MAX
A	2.035	2.065	51.69	52.45
B	0.540	0.560	13.72	14.22
C	0.155	0.200	3.94	5.08
D	0.014	0.022	0.36	0.56
E	0.035 BSC		0.89 BSC	
F	0.032	0.046	0.81	1.17
G	0.070 BSC		1.778 BSC	
H	0.300 BSC		7.62 BSC	
J	0.008	0.015	0.20	0.38
K	0.115	0.135	2.92	3.43
L	0.600 BSC		15.24 BSC	
M	0°	15°	0°	15°
N	0.020	0.040	0.51	1.02

FB, FTB SUFFIX
CASE 873-01
 Plastic Package
 (TQFP-32)
 ISSUE A

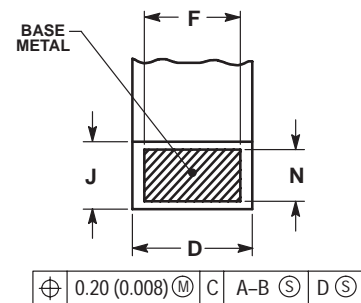
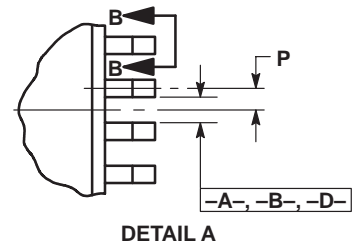
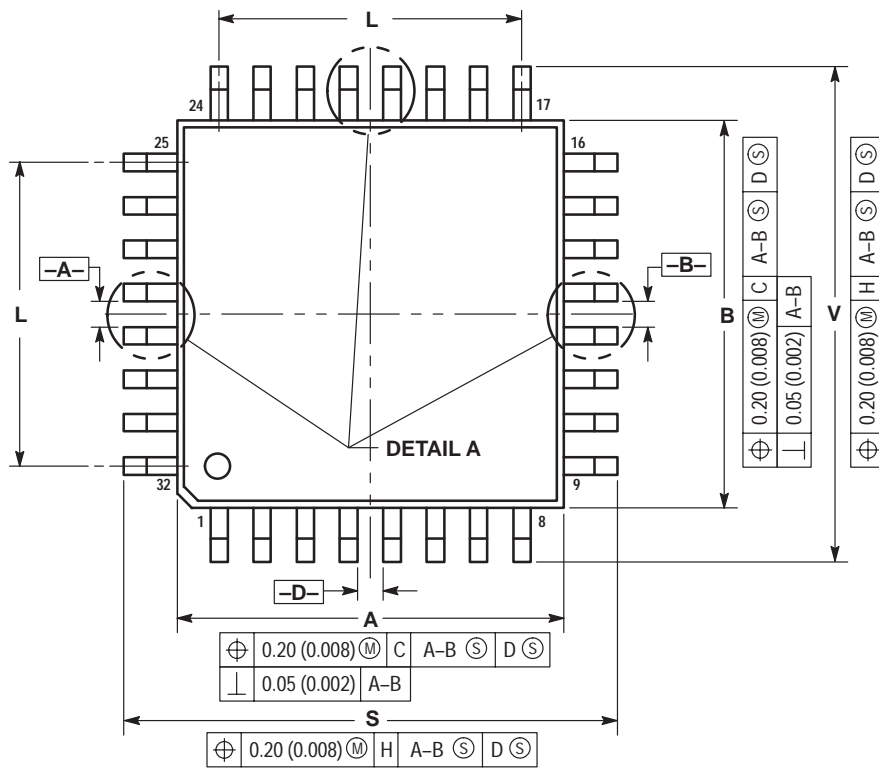
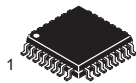

SECTION B-B
 VIEW ROTATED 90° CLOCKWISE

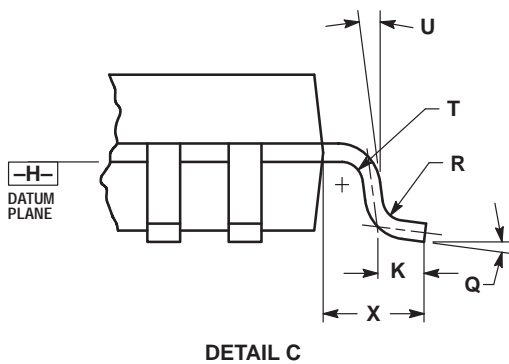
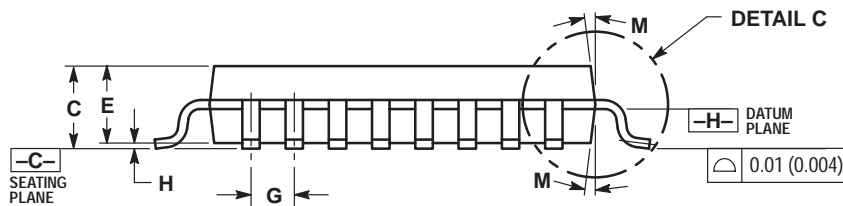

NOTES:

1. DIMENSION AND TOLERANCING PER ANSI Y14.5M, 1982.
2. CONTROLLING DIMENSION: MILLIMETER.
3. DATUM PLANE -H- IS LOCATED AT BOTTOM OF LEAD AND IS COINCIDENT WITH THE LEAD WHERE THE LEAD EXITS THE PLASTIC BODY AT THE BOTTOM OF THE PARTING LINE.
4. DATUMS -A-, -B- AND -D- TO BE DETERMINED AT DATUM PLANE -H-.
5. DIMENSIONS S AND V TO BE DETERMINED AT SEATING PLANE -C-.
6. DIMENSIONS A AND B DO NOT INCLUDE MOLD PROTRUSION. ALLOWABLE PROTRUSION IS 0.25 (0.010) PER SIDE. DIMENSIONS A AND B DO INCLUDE MOLD MISMATCH AND ARE DETERMINED AT DATUM PLANE -H-.
7. DIMENSION D DOES NOT INCLUDE DAMBAR PROTRUSION. ALLOWABLE DAMBAR PROTRUSION SHALL BE 0.08 (0.003) TOTAL IN EXCESS OF THE D DIMENSION AT MAXIMUM MATERIAL CONDITION. DAMBAR CANNOT BE LOCATED ON THE LOWER RADIUS OR THE FOOT.

DIM	MILLIMETERS		INCHES	
	MIN	MAX	MIN	MAX
A	6.95	7.10	0.274	0.280
B	6.95	7.10	0.274	0.280
C	1.40	1.60	0.055	0.063
D	0.273	0.373	0.010	0.015
E	1.30	1.50	0.051	0.059
F	0.273	---	0.010	---
G	0.80	BSC	0.031	BSC
H	---	0.20	---	0.008
J	0.119	0.197	0.005	0.008
K	0.33	0.57	0.013	0.022
L	5.6	REF	0.220	REF
M	6°	8°	6°	8°
N	0.119	0.135	0.005	0.005
P	0.40	BSC	0.016	BSC
Q	5°	10°	5°	10°
R	0.15	0.25	0.006	0.010
S	8.85	9.15	0.348	0.360
T	0.15	0.25	0.006	0.010
U	5°	11°	5°	11°
V	8.85	9.15	0.348	0.360
X	1.00	REF	0.039	REF

T SUFFIX
CASE 894-03
 Plastic Package
 (23-Pin SZIP)
 ISSUE B

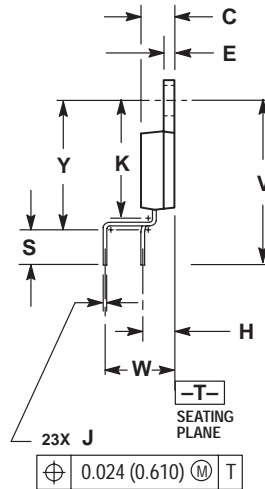
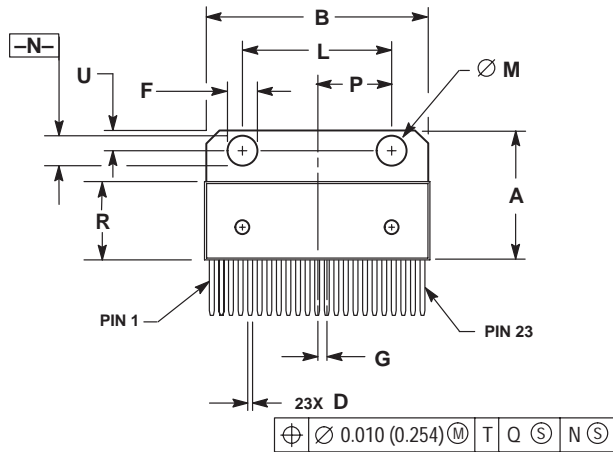
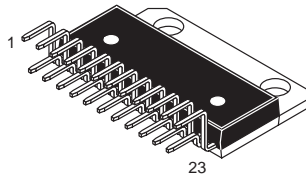

NOTES:

1. DIMENSIONING AND TOLERANCING PER ANSI Y14.5M, 1982.
2. CONTROLLING DIMENSION: INCH.
3. DIMENSION R DOES NOT INCLUDE MOLD FLASH OR PROTRUSIONS.
4. DIMENSION B DOES NOT INCLUDE MOLD FLASH OR PROTRUSIONS.
5. MOLD FLASH OR PROTRUSIONS SHALL NOT EXCEED 0.010 (0.250).
6. DIMENSION D DOES NOT INCLUDE DAMBAR PROTRUSION. ALLOWABLE PROTRUSION SHALL BE 0.003 (0.076) TOTAL IN EXCESS OF THE D DIMENSION AT MAXIMUM MATERIAL CONDITION.

DIM	INCHES		MILLIMETERS	
	MIN	MAX	MIN	MAX
A	0.684	0.694	17.374	17.627
B	1.183	1.193	30.048	30.302
C	0.175	0.179	4.445	4.547
D	0.026	0.031	0.660	0.787
E	0.058	0.062	1.473	1.574
F	0.165	0.175	4.191	4.445
G	0.050 BSC		1.270 BSC	
H	0.169 BSC		4.293 BSC	
J	0.014	0.020	0.356	0.508
K	0.625	0.639	15.875	16.231
L	0.770	0.790	19.558	20.066
M	0.148	0.152	3.760	3.861
N	0.148	0.152	3.760	3.861
P	0.390 BSC		9.906 BSC	
R	0.416	0.424	10.566	10.770
S	0.157	0.167	3.988	4.242
U	0.105	0.115	2.667	2.921
V	0.868 REF		22.047 REF	
W	0.200 BSC		5.080 BSC	
Y	0.700	0.710	17.780	18.034

FTA SUFFIX
CASE 932-02
 Plastic Package
 (TQFP-48)
 ISSUE D

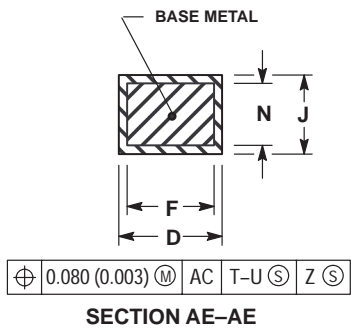
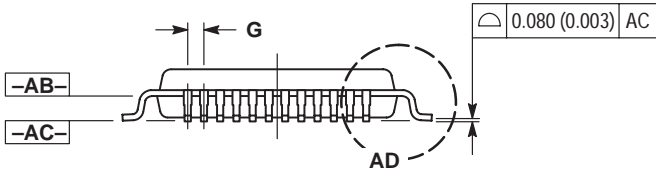
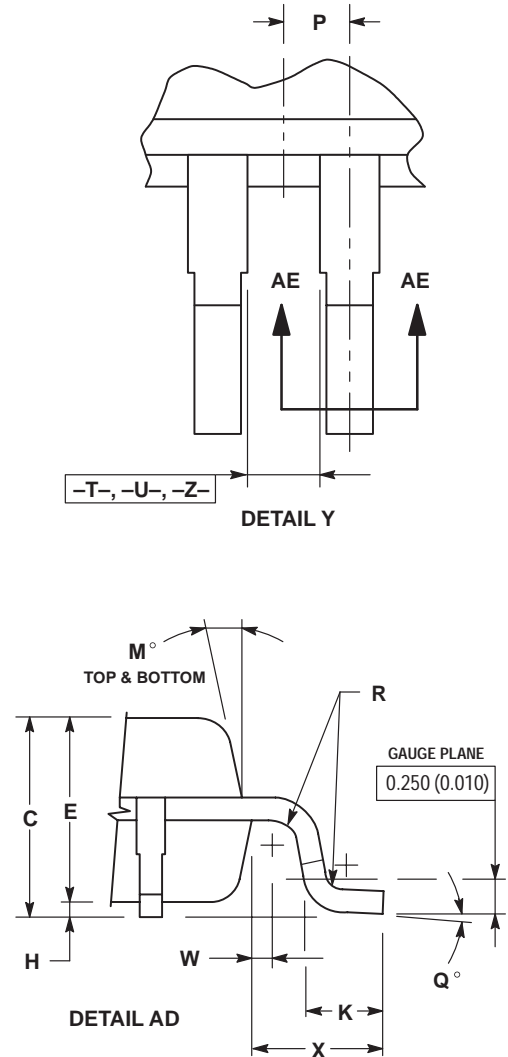
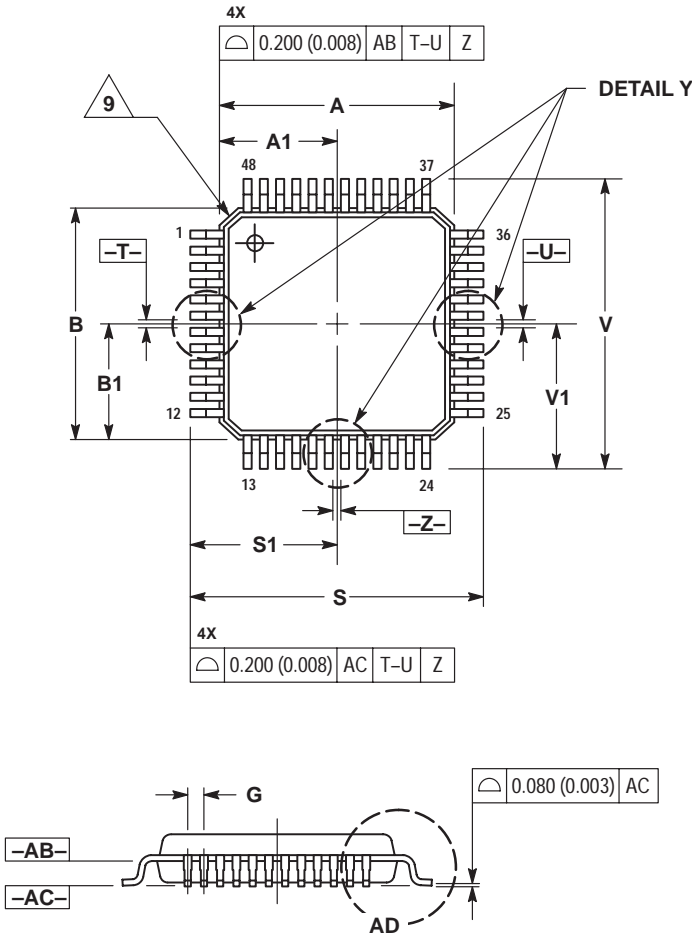
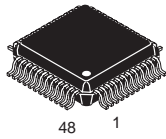

- NOTES:
1. DIMENSIONING AND TOLERANCING PER ANSI Y14.5M, 1982.
 2. CONTROLLING DIMENSION: MILLIMETER.
 3. DATUM PLANE -AB- IS LOCATED AT BOTTOM OF LEAD AND IS COINCIDENT WITH THE LEAD WHERE THE LEAD EXITS THE PLASTIC BODY AT THE BOTTOM OF THE PARTING LINE.
 4. DATUMS -T-, -U-, AND -Z- TO BE DETERMINED AT DATUM PLANE -AB-.
 5. DIMENSIONS S AND V TO BE DETERMINED AT SEATING PLANE -AC-.
 6. DIMENSIONS A AND B DO NOT INCLUDE MOLD PROTRUSION. ALLOWABLE PROTRUSION IS 0.250 (0.010) PER SIDE. DIMENSIONS A AND B DO NOT INCLUDE MOLD MISMATCH AND ARE DETERMINED AT DATUM PLANE -AB-.
 7. DIMENSION D DOES NOT INCLUDE DAMBAR PROTRUSION. DAMBAR PROTRUSION SHALL NOT CAUSE THE D DIMENSION TO EXCEED 0.350 (0.014).
 8. MINIMUM SOLDER PLATE THICKNESS SHALL BE 0.0076 (0.0003).
 9. EXACT SHAPE OF EACH CORNER IS OPTIONAL.

DIM	MILLIMETERS		INCHES	
	MIN	MAX	MIN	MAX
A	7.000 BSC		0.276 BSC	
A1	3.500 BSC		0.138 BSC	
B	7.000 BSC		0.276 BSC	
B1	3.500 BSC		0.138 BSC	
C	1.400	1.600	0.055	0.063
D	0.170	0.270	0.007	0.011
E	1.350	1.450	0.053	0.057
F	0.170	0.230	0.007	0.009
G	0.500 BASIC		0.020 BASIC	
H	0.050	0.150	0.002	0.006
J	0.090	0.200	0.004	0.008
K	0.500	0.700	0.020	0.028
M	12° REF		12° REF	
N	0.090	0.160	0.004	0.006
P	0.250 BASIC		0.010 BASIC	
Q	1°	5°	1°	5°
R	0.150	0.250	0.006	0.010
S	9.000 BSC		0.354 BSC	
S1	4.500 BSC		0.177 BSC	
V	9.000 BSC		0.354 BSC	
V1	4.500 BSC		0.177 BSC	
W	0.200 REF		0.008 REF	
X	1.000 REF		0.039 REF	

D2T SUFFIX
CASE 936-03
 Plastic Package
 ISSUE B

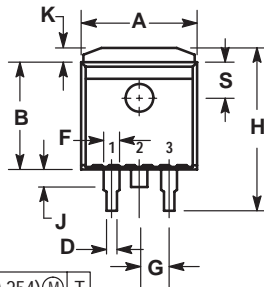
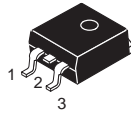

$\oplus 0.010 (0.254) \text{M} \text{T}$

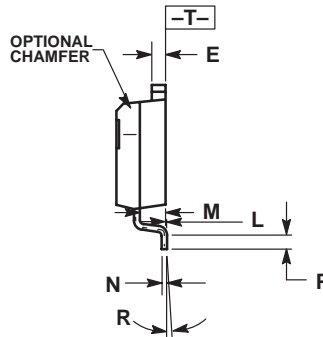
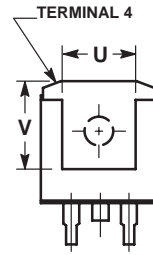
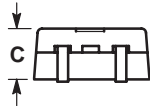

- NOTES:
1. DIMENSIONING AND TOLERANCING PER ANSI Y14.5M, 1982.
 2. CONTROLLING DIMENSION: INCH.
 3. TAB CONTOUR OPTIONAL WITHIN DIMENSIONS A AND K.
 4. DIMENSIONS U AND V ESTABLISH A MINIMUM MOUNTING SURFACE FOR TERMINAL 4.
 5. DIMENSIONS A AND B DO NOT INCLUDE MOLD FLASH OR GATE PROTRUSIONS. MOLD FLASH AND GATE PROTRUSIONS NOT TO EXCEED 0.025 (0.635) MAXIMUM.

DIM	INCHES		MILLIMETERS	
	MIN	MAX	MIN	MAX
A	0.386	0.403	9.804	10.236
B	0.356	0.368	9.042	9.347
C	0.170	0.180	4.318	4.572
D	0.026	0.036	0.660	0.914
E	0.045	0.055	1.143	1.397
F	0.051 REF		1.295 REF	
G	0.100 BSC		2.540 BSC	
H	0.539	0.579	13.691	14.707
J	0.125 MAX		3.175 MAX	
K	0.050 REF		1.270 REF	
L	0.000	0.010	0.000	0.254
M	0.088	0.102	2.235	2.591
N	0.018	0.026	0.457	0.660
P	0.058	0.078	1.473	1.981
R	5° REF		5° REF	
S	0.116 REF		2.946 REF	
U	0.200 MIN		5.080 MIN	
V	0.250 MIN		6.350 MIN	

D2T SUFFIX
CASE 936A-02
 Plastic Package
 (D²PAK)
 ISSUE A

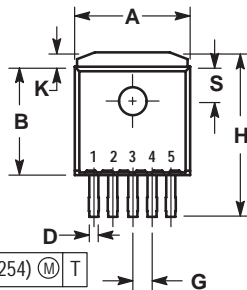
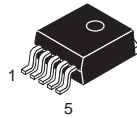

$\oplus 0.010 (0.254) \text{M} \text{T}$

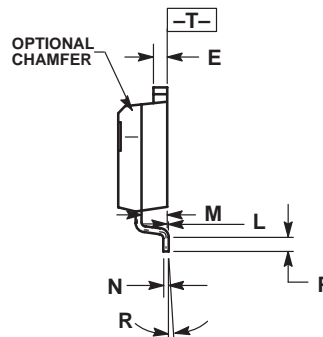
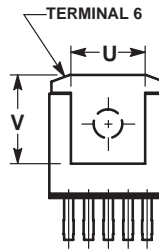
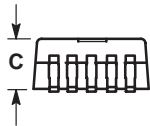

- NOTES:
1. DIMENSIONING AND TOLERANCING PER ANSI Y14.5M, 1982.
 2. CONTROLLING DIMENSION: INCH.
 3. TAB CONTOUR OPTIONAL WITHIN DIMENSIONS A AND K.
 4. DIMENSIONS U AND V ESTABLISH A MINIMUM MOUNTING SURFACE FOR TERMINAL 6.
 5. DIMENSIONS A AND B DO NOT INCLUDE MOLD FLASH OR GATE PROTRUSIONS. MOLD FLASH AND GATE PROTRUSIONS NOT TO EXCEED 0.025 (0.635) MAXIMUM.

DIM	INCHES		MILLIMETERS	
	MIN	MAX	MIN	MAX
A	0.386	0.403	9.804	10.236
B	0.356	0.368	9.042	9.347
C	0.170	0.180	4.318	4.572
D	0.026	0.036	0.660	0.914
E	0.045	0.055	1.143	1.397
G	0.067 BSC		1.702 BSC	
H	0.539	0.579	13.691	14.707
K	0.050 REF		1.270 REF	
L	0.000	0.010	0.000	0.254
M	0.088	0.102	2.235	2.591
N	0.018	0.026	0.457	0.660
P	0.058	0.078	1.473	1.981
R	5° REF		5° REF	
S	0.116 REF		2.946 REF	
U	0.200 MIN		5.080 MIN	
V	0.250 MIN		6.350 MIN	

DT, DTB SUFFIX
CASE 948E-02
 Plastic Package
 (TSSOP-20)
 ISSUE A

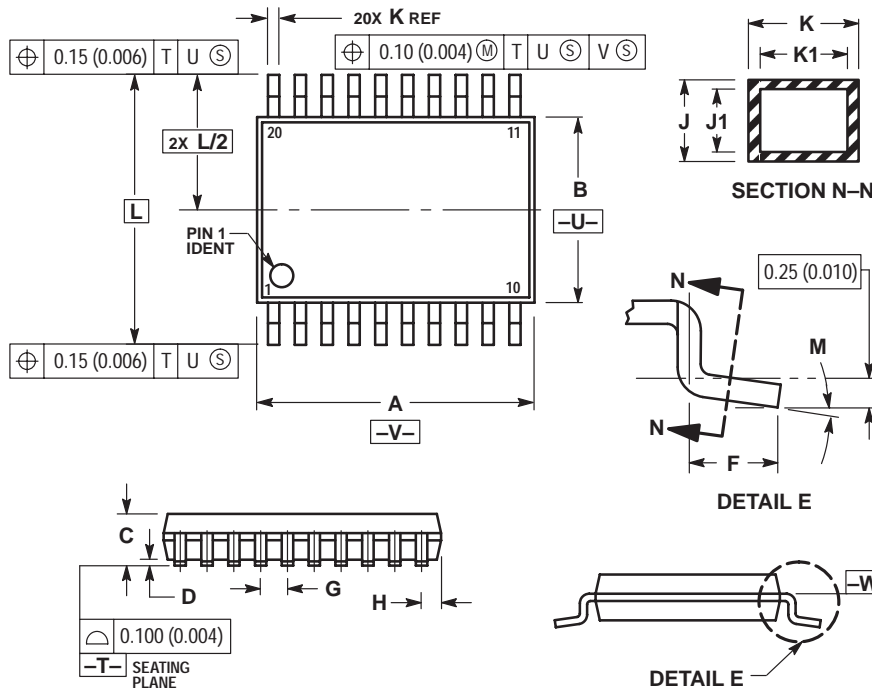
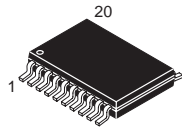

- NOTES:
1. DIMENSIONING AND TOLERANCING PER ANSI Y14.5M, 1982.
 2. CONTROLLING DIMENSION: MILLIMETER.
 3. DIMENSION A DOES NOT INCLUDE MOLD FLASH, PROTRUSIONS OR GATE BURRS. MOLD FLASH OR GATE BURRS SHALL NOT EXCEED 0.15 (0.006) PER SIDE.
 4. DIMENSION B DOES NOT INCLUDE INTERLEAD FLASH OR PROTRUSION. INTERLEAD FLASH OR PROTRUSION SHALL NOT EXCEED 0.25 (0.010) PER SIDE.
 5. DIMENSION K DOES NOT INCLUDE DAMBAR PROTRUSION. ALLOWABLE DAMBAR PROTRUSION SHALL BE 0.08 (0.003) TOTAL IN EXCESS OF THE K DIMENSION AT MAXIMUM MATERIAL CONDITION.
 6. TERMINAL NUMBERS ARE SHOWN FOR REFERENCE ONLY.
 7. DIMENSION A AND B ARE TO BE DETERMINED AT DATUM PLANE -W-.

DIM	MILLIMETERS		INCHES	
	MIN	MAX	MIN	MAX
A	6.40	6.60	0.252	0.260
B	4.30	4.50	0.169	0.177
C	---	1.20	---	0.047
D	0.05	0.15	0.002	0.006
F	0.50	0.75	0.020	0.030
G	0.65 BSC		0.026 BSC	
H	0.27	0.37	0.011	0.015
J	0.09	0.20	0.004	0.008
J1	0.09	0.16	0.004	0.006
K	0.19	0.30	0.007	0.012
K1	0.19	0.25	0.007	0.010
L	6.40 BSC		0.252 BSC	
M	0°	8°	0°	8°

DTB SUFFIX
CASE 948F-01
 Plastic Package
 (TSSOP-16, TSSOP-16L)
 ISSUE O

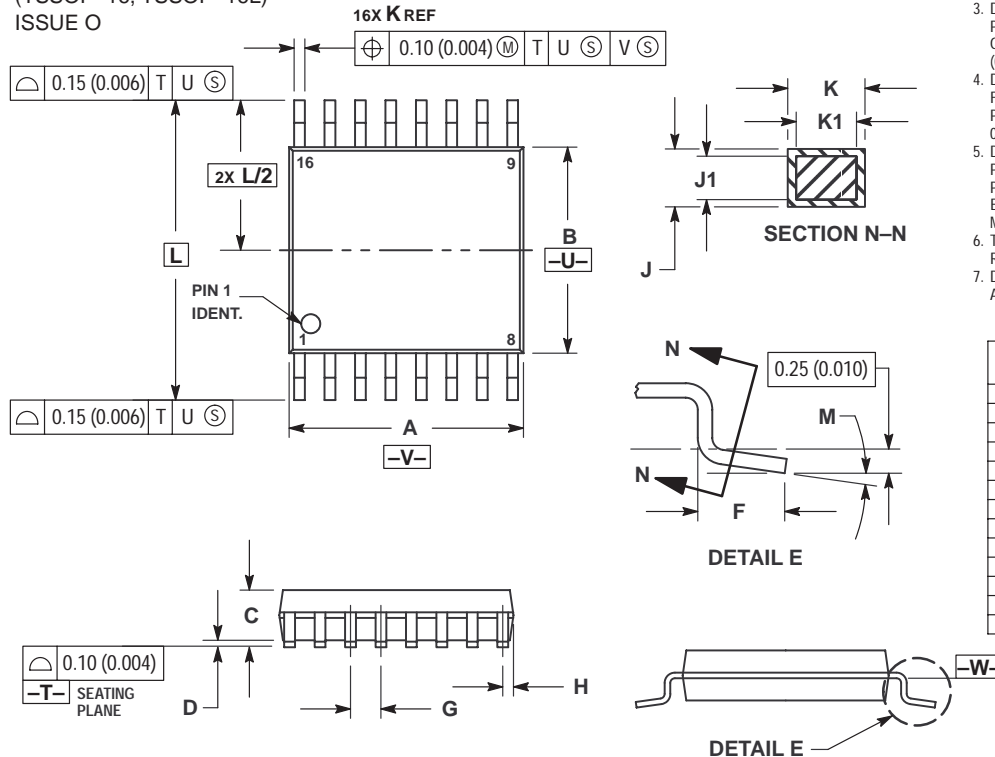
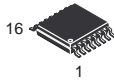

- NOTES:
1. DIMENSIONING AND TOLERANCING PER ANSI Y14.5M, 1982.
 2. CONTROLLING DIMENSION: MILLIMETER.
 3. DIMENSION A DOES NOT INCLUDE MOLD FLASH, PROTRUSIONS OR GATE BURRS. MOLD FLASH OR GATE BURRS SHALL NOT EXCEED 0.15 (0.006) PER SIDE.
 4. DIMENSION B DOES NOT INCLUDE INTERLEAD FLASH OR PROTRUSION. INTERLEAD FLASH OR PROTRUSION SHALL NOT EXCEED 0.25 (0.010) PER SIDE.
 5. DIMENSION K DOES NOT INCLUDE DAMBAR PROTRUSION. ALLOWABLE DAMBAR PROTRUSION SHALL BE 0.08 (0.003) TOTAL IN EXCESS OF THE K DIMENSION AT MAXIMUM MATERIAL CONDITION.
 6. TERMINAL NUMBERS ARE SHOWN FOR REFERENCE ONLY.
 7. DIMENSION A AND B ARE TO BE DETERMINED AT DATUM PLANE -W-.

DIM	MILLIMETERS		INCHES	
	MIN	MAX	MIN	MAX
A	4.90	5.10	0.193	0.200
B	4.30	4.50	0.169	0.177
C	---	1.20	---	0.047
D	0.05	0.15	0.002	0.006
F	0.50	0.75	0.020	0.030
G	0.65 BSC		0.026 BSC	
H	0.18	0.28	0.007	0.011
J	0.09	0.20	0.004	0.008
J1	0.09	0.16	0.004	0.006
K	0.19	0.30	0.007	0.012
K1	0.19	0.25	0.007	0.010
L	6.40 BSC		0.252 BSC	
M	0°	8°	0°	8°

DTB SUFFIX
CASE 948G-01
 Plastic Package
 (TSSOP-14)
 ISSUE O

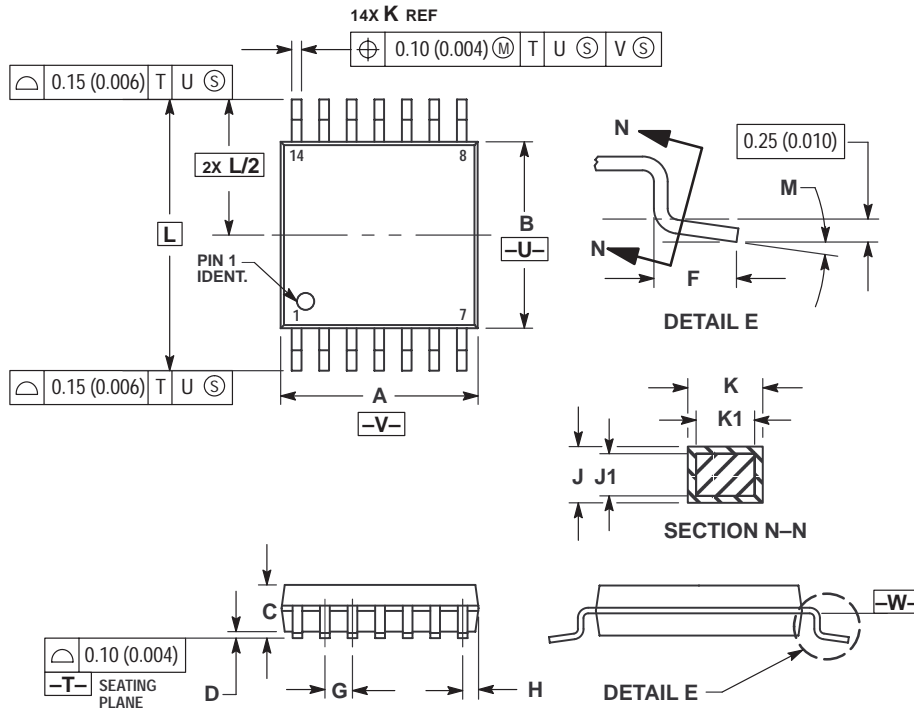

NOTES:

- 1 DIMENSIONING AND TOLERANCING PER ANSI Y14.5M, 1982.
- 2 CONTROLLING DIMENSION: MILLIMETER.
- 3 DIMENSION A DOES NOT INCLUDE MOLD FLASH, PROTRUSIONS OR GATE BURRS. MOLD FLASH OR GATE BURRS SHALL NOT EXCEED 0.15 (0.006) PER SIDE.
- 4 DIMENSION B DOES NOT INCLUDE INTERLEAD FLASH OR PROTRUSION. INTERLEAD FLASH OR PROTRUSION SHALL NOT EXCEED 0.25 (0.010) PER SIDE.
- 5 DIMENSION K DOES NOT INCLUDE DAMBAR PROTRUSION. ALLOWABLE DAMBAR PROTRUSION SHALL BE 0.08 (0.003) TOTAL IN EXCESS OF THE K DIMENSION AT MAXIMUM MATERIAL CONDITION.
- 6 TERMINAL NUMBERS ARE SHOWN FOR REFERENCE ONLY.
- 7 DIMENSION A AND B ARE TO BE DETERMINED AT DATUM PLANE -W-.

DIM	MILLIMETERS		INCHES	
	MIN	MAX	MIN	MAX
A	4.90	5.10	0.193	0.200
B	4.30	4.50	0.169	0.177
C	---	1.20	---	0.047
D	0.05	0.15	0.002	0.006
F	0.50	0.75	0.020	0.030
G	0.65 BSC		0.026 BSC	
H	0.50	0.60	0.020	0.024
J	0.09	0.20	0.004	0.008
J1	0.09	0.16	0.004	0.006
K	0.19	0.30	0.007	0.012
K1	0.19	0.25	0.007	0.010
L	6.40 BSC		0.252 BSC	
M	0°	8°	0°	8°

DTB SUFFIX
CASE 948H-01
 Plastic Package
 ISSUE O

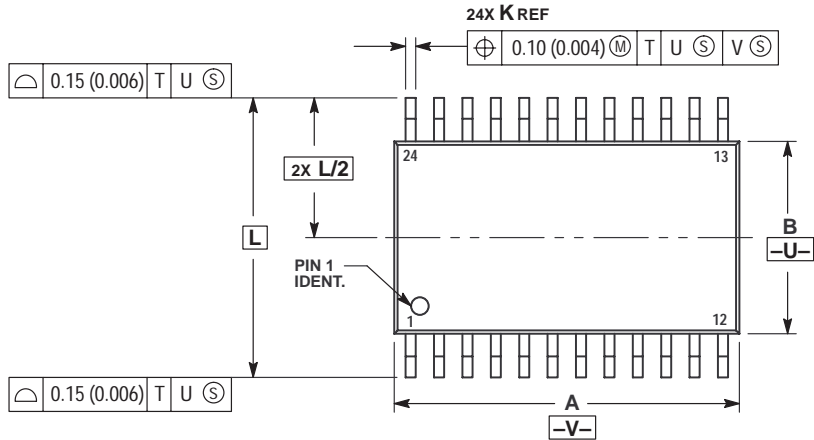
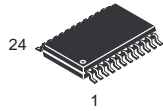

- NOTES:
1. DIMENSIONING AND TOLERANCING PER ANSI Y14.5M, 1982.
 2. CONTROLLING DIMENSION: MILLIMETER.
 3. DIMENSION A DOES NOT INCLUDE MOLD FLASH, PROTRUSIONS OR GATE BURRS. MOLD FLASH OR GATE BURRS SHALL NOT EXCEED 0.15 (0.006) PER SIDE.
 4. DIMENSION B DOES NOT INCLUDE INTERLEAD FLASH OR PROTRUSION. INTERLEAD FLASH OR PROTRUSION SHALL NOT EXCEED 0.25 (0.010) PER SIDE.
 5. DIMENSION K DOES NOT INCLUDE DAMBAR PROTRUSION. ALLOWABLE DAMBAR PROTRUSION SHALL BE 0.08 (0.003) TOTAL IN EXCESS OF THE K DIMENSION AT MAXIMUM MATERIAL CONDITION.
 6. TERMINAL NUMBERS ARE SHOWN FOR REFERENCE ONLY.
 7. DIMENSION A AND B ARE TO BE DETERMINED AT DATUM PLANE -W-.

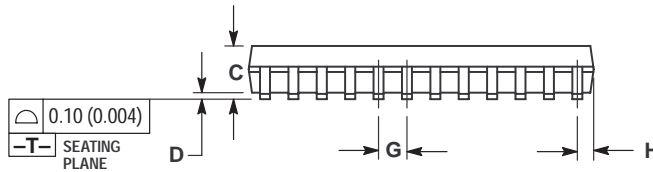

DIM	MILLIMETERS		INCHES	
	MIN	MAX	MIN	MAX
A	7.70	7.90	0.303	0.311
B	4.30	4.50	0.169	0.177
C	---	1.20	---	0.047
D	0.05	0.15	0.002	0.006
F	0.50	0.75	0.020	0.030
G	0.65 BSC		0.026 BSC	
H	0.27	0.37	0.011	0.015
J	0.09	0.20	0.004	0.008
J1	0.09	0.16	0.004	0.006
K	0.19	0.30	0.007	0.012
K1	0.19	0.25	0.007	0.010
L	6.40 BSC		0.252 BSC	
M	0°	8°	0°	8°

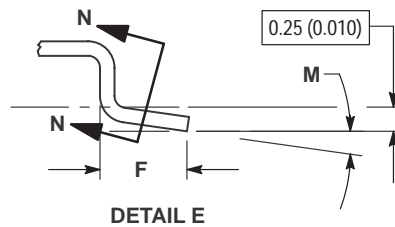
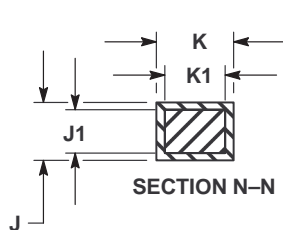
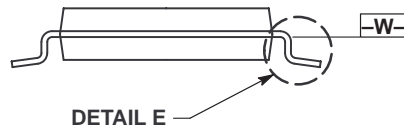

DTB SUFFIX
CASE 948J-01
 Plastic Package
 (TSSOP-8)
 ISSUE O

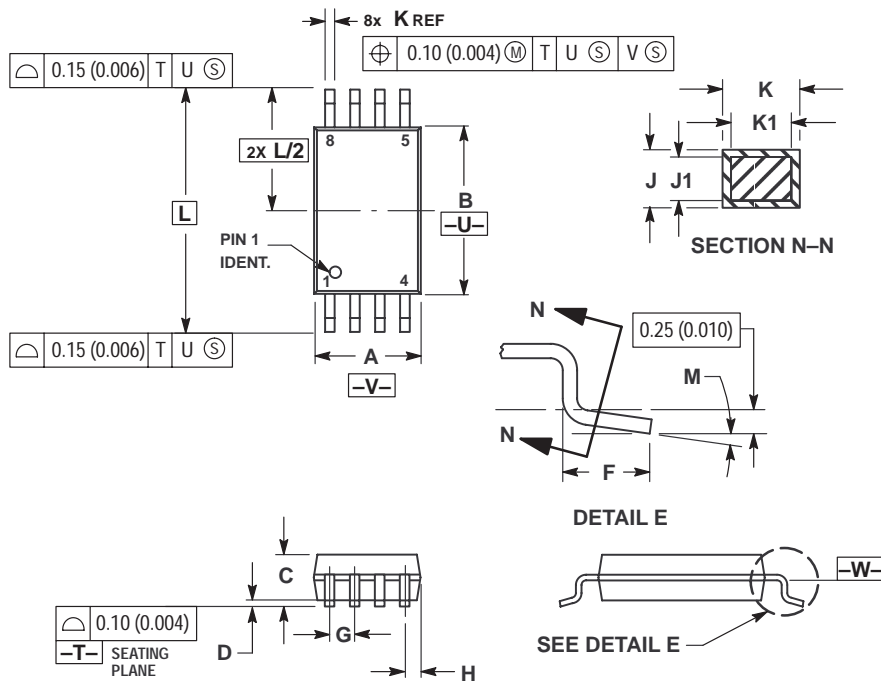

- NOTES:
- 1 DIMENSIONING AND TOLERANCING PER ANSI Y14.5M, 1982.
 - 2 CONTROLLING DIMENSION: MILLIMETER.
 - 3 DIMENSION A DOES NOT INCLUDE MOLD FLASH, PROTRUSIONS OR GATE BURRS. MOLD FLASH OR GATE BURRS SHALL NOT EXCEED 0.15 (0.006) PER SIDE.
 - 4 DIMENSION B DOES NOT INCLUDE INTERLEAD FLASH OR PROTRUSION. INTERLEAD FLASH OR PROTRUSION SHALL NOT EXCEED 0.25 (0.010) PER SIDE.
 - 5 DIMENSION K DOES NOT INCLUDE DAMBAR PROTRUSION. ALLOWABLE DAMBAR PROTRUSION SHALL BE 0.08 (0.003) TOTAL IN EXCESS OF THE K DIMENSION AT MAXIMUM MATERIAL CONDITION.
 - 6 TERMINAL NUMBERS ARE SHOWN FOR REFERENCE ONLY.
 - 7 DIMENSION A AND B ARE TO BE DETERMINED AT DATUM PLANE -W-.

DIM	MILLIMETERS		INCHES	
	MIN	MAX	MIN	MAX
A	2.90	3.10	0.114	0.122
B	4.30	4.50	0.169	0.177
C	---	1.20	---	0.047
D	0.05	0.15	0.002	0.006
F	0.50	0.75	0.020	0.030
G	0.65 BSC		0.026 BSC	
H	0.50	0.60	0.020	0.024
J	0.09	0.20	0.004	0.008
J1	0.09	0.16	0.004	0.006
K	0.19	0.30	0.007	0.012
K1	0.19	0.25	0.007	0.010
L	6.40 BSC		0.252 BSC	
M	0°	8°	0°	8°

M SUFFIX
CASE 967-01
 Plastic Package
 (EIAJ-20)
 ISSUE O

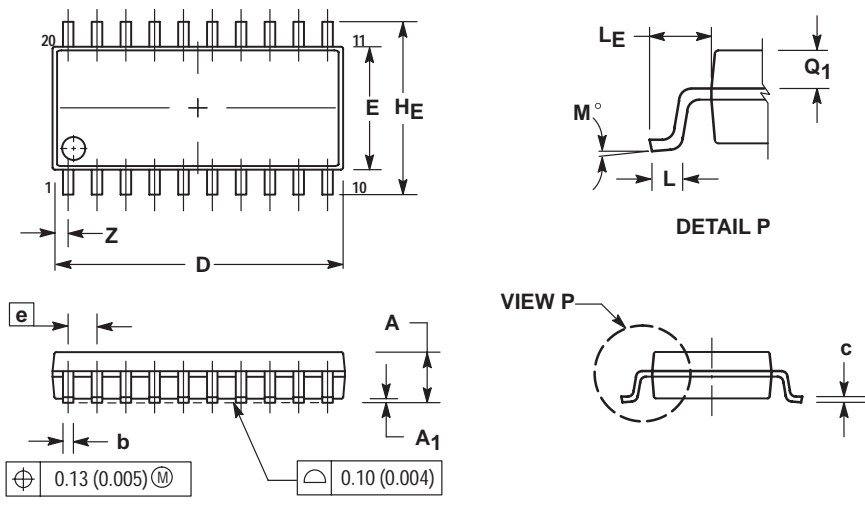
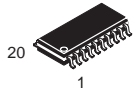

- NOTES:
- 1 DIMENSIONING AND TOLERANCING PER ANSI Y14.5M, 1982.
 - 2 CONTROLLING DIMENSION: MILLIMETER.
 - 3 DIMENSIONS D AND E DO NOT INCLUDE MOLD FLASH OR PROTRUSIONS AND ARE MEASURED AT THE PARTING LINE. MOLD FLASH OR PROTRUSIONS SHALL NOT EXCEED 0.15 (0.006) PER SIDE.
 - 4 TERMINAL NUMBERS ARE SHOWN FOR REFERENCE ONLY.
 - 5 THE LEAD WIDTH DIMENSION (b) DOES NOT INCLUDE DAMBAR PROTRUSION. ALLOWABLE DAMBAR PROTRUSION SHALL BE 0.08 (0.003) TOTAL IN EXCESS OF THE LEAD WIDTH DIMENSION AT MAXIMUM MATERIAL CONDITION. DAMBAR CANNOT BE LOCATED ON THE LOWER RADIUS OR THE FOOT. MINIMUM SPACE BETWEEN PROTRUSIONS AND ADJACENT LEAD TO BE 0.46 (0.018).

DIM	MILLIMETERS		INCHES	
	MIN	MAX	MIN	MAX
A	---	2.05	---	0.081
A1	0.05	0.20	0.002	0.008
b	0.35	0.50	0.014	0.020
c	0.18	0.27	0.007	0.011
D	12.35	12.80	0.486	0.504
E	5.10	5.45	0.201	0.215
e	1.27 BSC		0.050 BSC	
H _F	7.40	8.20	0.291	0.323
L	0.50	0.85	0.020	0.033
L _F	1.10	1.50	0.043	0.059
M	0°	10°	0°	10°
Q ₁	0.70	0.90	0.028	0.035
Z	---	0.81	---	0.032

FTB SUFFIX
CASE 976-01
Plastic Package
(TQFP-20)
ISSUE O

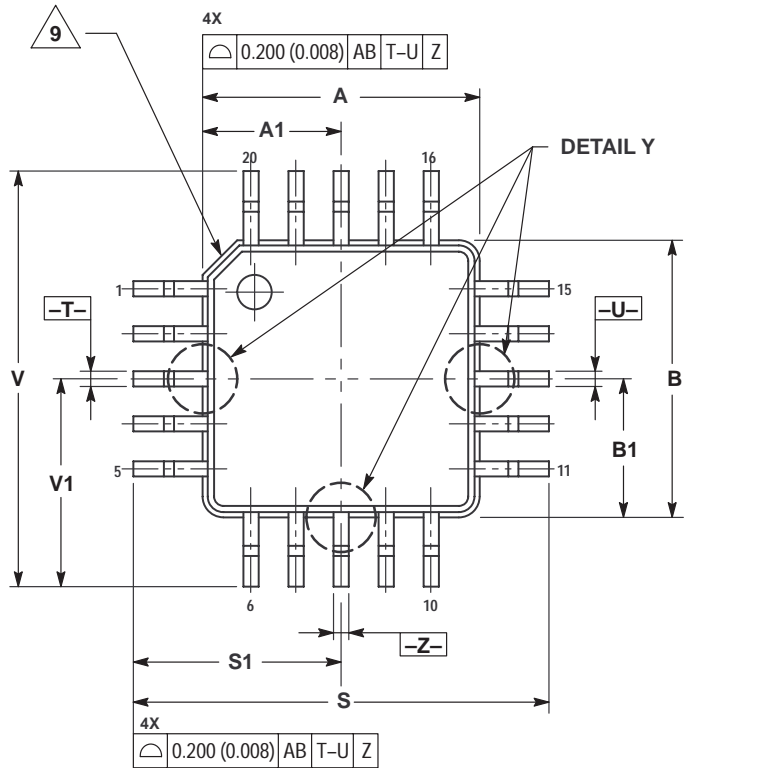
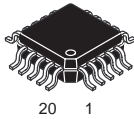

- NOTES:
1. DIMENSIONING AND TOLERANCING PER ANSI Y14.5M, 1982.
 2. CONTROLLING DIMENSION: MILLIMETER.
 3. DATUM PLANE -AB- IS LOCATED AT BOTTOM OF LEAD AND IS COINCIDENT WITH THE LEAD WHERE THE LEAD EXITS THE PLASTIC BODY AT THE BOTTOM OF THE PARTING LINE.
 4. DATUMS -T-, -U-, AND -Z- TO BE DETERMINED AT DATUM PLANE -AB-.
 5. DIMENSIONS S AND V TO BE DETERMINED AT DATUM PLANE -AC-.
 6. DIMENSIONS A AND B DO NOT INCLUDE MOLD PROTRUSION. ALLOWABLE PROTRUSION IS 0.250 (0.010) PER SIDE. DIMENSIONS A AND B DO INCLUDE MOLD MISMATCH AND ARE DETERMINED AT DATUM PLANE -AB-.
 7. DIMENSION D DOES NOT INCLUDE DAMBAR PROTRUSION. DAMBAR PROTRUSION SHALL NOT CAUSE THE D DIMENSION TO EXCEED 0.350 (0.014).
 8. MINIMUM SOLDER PLATE THICKNESS SHALL BE 0.0076 (0.0003).
 9. EXACT SHAPE OF EACH CORNER IS OPTIONAL.

DIM	MILLIMETERS		INCHES	
	MIN	MAX	MIN	MAX
A	4.000	BSC	0.157	BSC
A1	2.000	BSC	0.079	BSC
B	4.000	BSC	0.157	BSC
B1	2.000	BSC	0.079	BSC
C	1.400	1.600	0.055	0.063
D	0.170	0.270	0.007	0.011
E	1.350	1.450	0.053	0.057
F	0.170	0.230	0.007	0.009
G	0.650	BSC	0.026	BSC
H	0.050	0.150	0.002	0.006
J	0.090	0.200	0.004	0.008
K	0.500	0.700	0.020	0.028
M	12°	REF	12°	REF
N	0.090	0.160	0.004	0.006
P	0.250	BSC	0.010	BSC
Q	1°	5°	1°	5°
R	0.150	0.250	0.006	0.010
S	6.000	BSC	0.236	BSC
S1	3.000	BSC	0.118	BSC
V	6.000	BSC	0.236	BSC
V1	3.000	BSC	0.118	BSC
W	0.200	REF	0.008	REF
X	1.000	REF	0.039	REF

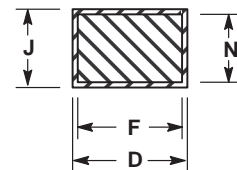
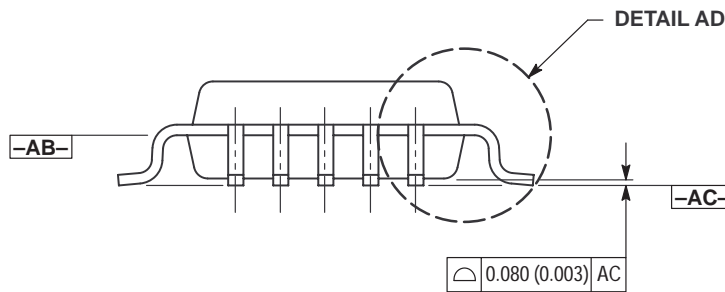

SECTION AE-AE

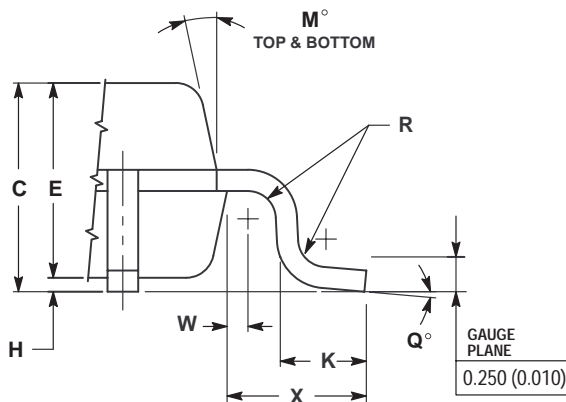

DETAIL AD

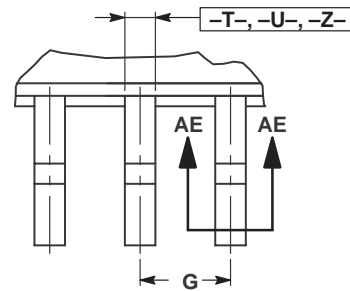

DETAIL Y

FTA SUFFIX
CASE 977-01
Plastic Package
ISSUE O

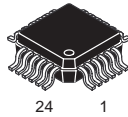

24 1

- NOTES:
1. DIMENSIONING AND TOLERANCING PER ANSI Y14.5M, 1982.
 2. CONTROLLING DIMENSION: MILLIMETER.
 3. DATUM PLANE -AB- IS LOCATED AT BOTTOM OF LEAD AND IS COINCIDENT WITH THE LEAD WHERE THE LEAD EXITS THE PLASTIC BODY AT THE BOTTOM OF THE PARTING LINE.
 4. DATUMS -T-, -U-, AND -Z- TO BE DETERMINED AT DATUM PLANE -AB-.
 5. DIMENSIONS S AND V TO BE DETERMINED AT DATUM PLANE -AC-.
 6. DIMENSIONS A AND B DO NOT INCLUDE MOLD PROTRUSION. ALLOWABLE PROTRUSION IS 0.250 (0.010) PER SIDE. DIMENSIONS A AND B DO INCLUDE MOLD MISMATCH AND ARE DETERMINED AT DATUM PLANE -AB-.
 7. DIMENSION D DOES NOT INCLUDE DAMBAR PROTRUSION. DAMBAR PROTRUSION SHALL NOT CAUSE THE D DIMENSION TO EXCEED 0.350 (0.014).
 8. MINIMUM SOLDER PLATE THICKNESS SHALL BE 0.0076 (0.0003).
 9. EXACT SHAPE OF EACH CORNER IS OPTIONAL.

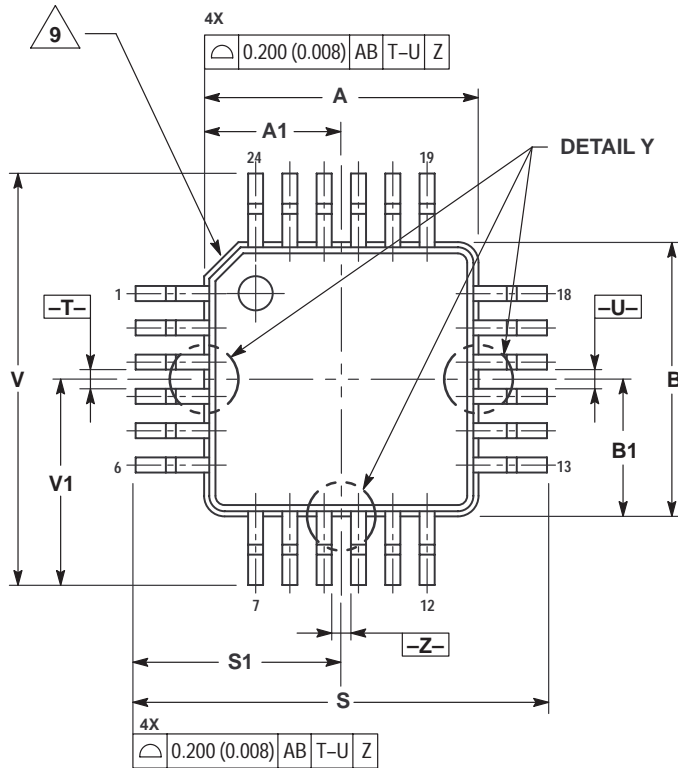

DIM	MILLIMETERS		INCHES	
	MIN	MAX	MIN	MAX
A	4.000 BSC		0.157 BSC	
A1	2.000 BSC		0.079 BSC	
B	4.000 BSC		0.157 BSC	
B1	2.000 BSC		0.079 BSC	
C	1.400	1.600	0.055	0.063
D	0.170	0.270	0.007	0.011
E	1.350	1.450	0.053	0.057
F	0.170	0.230	0.007	0.009
G	0.500 BSC		0.020 BSC	
H	0.050	0.150	0.002	0.006
J	0.090	0.200	0.004	0.008
K	0.500	0.700	0.020	0.028
M	12° REF		12° REF	
N	0.090	0.160	0.004	0.006
P	0.250 BSC		0.010 BSC	
Q	1°	5°	1°	5°
R	0.150	0.250	0.006	0.010
S	6.000 BSC		0.236 BSC	
S1	3.000 BSC		0.118 BSC	
V	6.000 BSC		0.236 BSC	
V1	3.000 BSC		0.118 BSC	
W	0.200 REF		0.008 REF	
X	1.000 REF		0.039 REF	

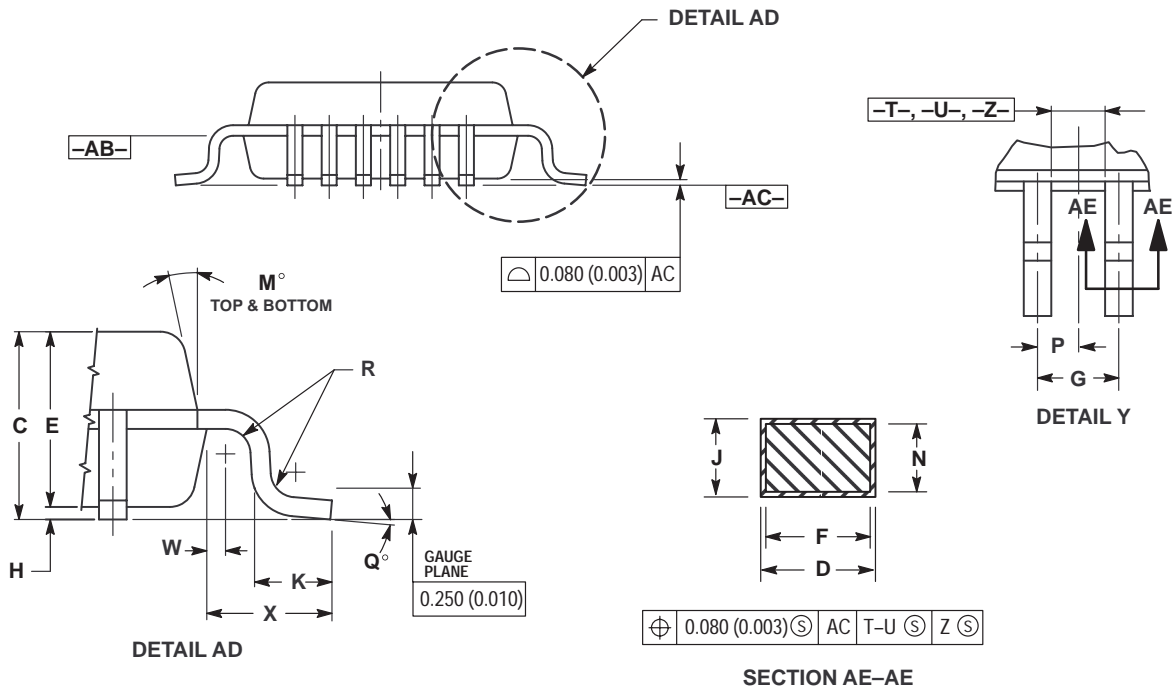

N SUFFIX
CASE 1212-01
 Plastic Package
 (SOT-23)
 ISSUE O

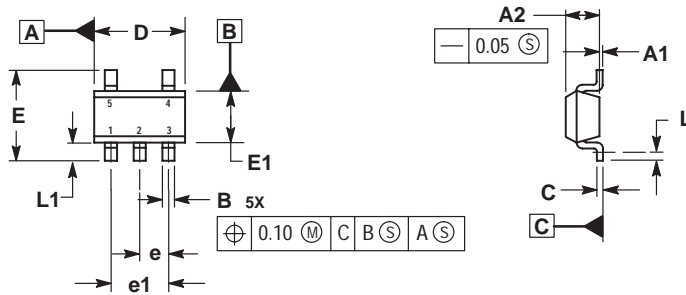

- NOTES:
 1. DIMENSIONS ARE IN MILLIMETERS.
 2. INTERPRET DIMENSIONS AND TOLERANCES PER ASME Y14.5M, 1994.
 3. DATUM C IS A SEATING PLANE.

MILLIMETERS		
DIM	MIN	MAX
A1	0.00	0.10
A2	1.00	1.30
B	0.30	0.50
C	0.10	0.25
D	2.80	3.00
E	2.50	3.10
E1	1.50	1.80
e	0.95 BSC	
e1	1.90 BSC	
L	0.20	----
L1	0.45	0.75

H SUFFIX
CASE 1213-01
 Plastic Package
 (SOT-89)
 ISSUE O

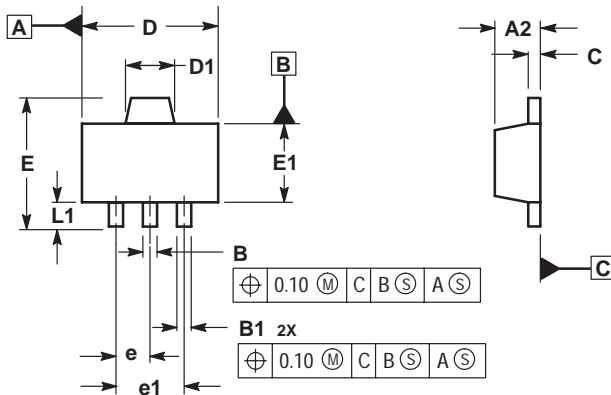

- NOTES:
 1. DIMENSIONS ARE IN MILLIMETERS.
 2. INTERPRET DIMENSIONS AND TOLERANCING PER ASME Y14.5M, 1994.
 3. DATUM C IS A SEATING PLANE.

MILLIMETERS		
DIM	MIN	MAX
A2	1.40	1.60
B	0.37	0.57
B1	0.32	0.52
C	0.30	0.50
D	4.40	4.60
D1	1.50	1.70
E	----	4.25
E1	2.40	2.60
e	1.50 BSC	
e1	3.00 BSC	
L1	0.80	----